

**Static Curtain Fire Damper - MODEL 152A**

**STANDARD CONSTRUCTION**

- FRAME**  
1-3/4" deep ID, 22 gauge galvanized steel
- BLADES**  
1-5/8" wide, 22 gauge galvanized steel
- UNDERSIZED**  
1/4" under ordered size unless specified otherwise
- FUSIBLE LINK**  
165° Standard (others available)
- SPRING**  
Stainless Steel – 301 Negator type
- MINIMUM SIZE**  
4"w x 4"h (Vertical Only)
- MAXIMUM SINGLE SECTION SIZE**  
30"w x 30"h (Vertical Only)

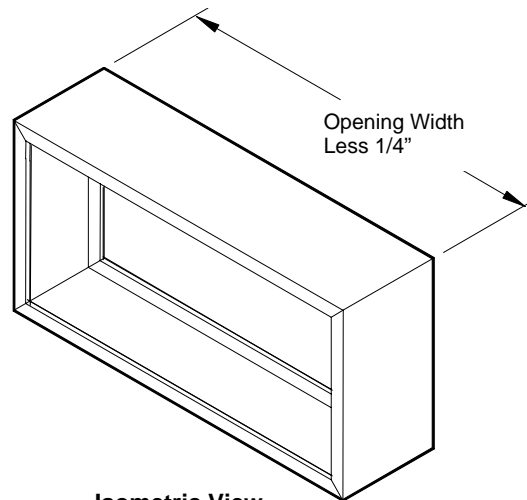

Isometric View

**OPTIONAL CONSTRUCTION**

- SPRING** - Available in vertical mount
- FRAME** - Available in Stainless Steel
- BLADE** - Available in Stainless Steel
- FUSIBLE LINK** - Electrically triggered link (ETL)
- SLEEVE & DUCT CONNECTION** - 10 ga. to 20 ga. galvanized steel to 30" in length. Transitions available in; round, oval, rectangular, or custom. Factory can install access door, retaining angles, flange connections or security bars.

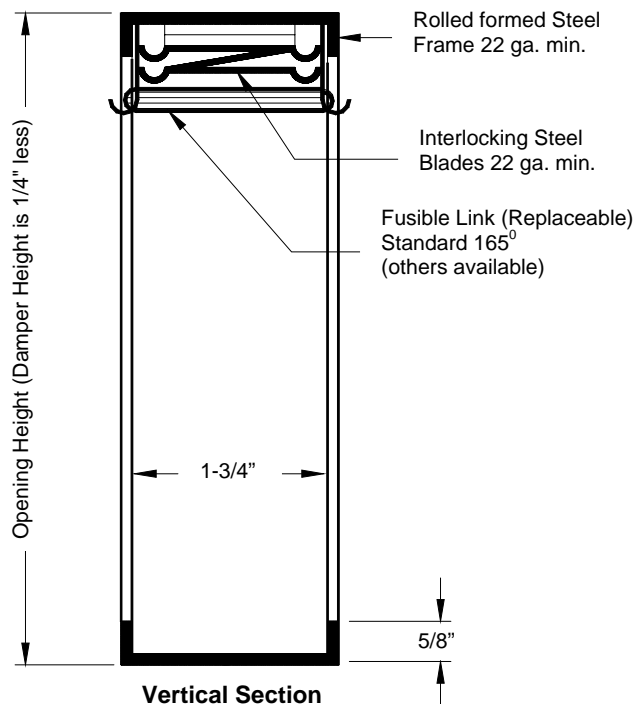

Vertical Section

DATE	ARCHITECT			CUSTOMER
PROJECT				
ITEM	QTY	W	H	DESCRIPTION