

**Monitoring Station & Test Station**

**Features** - Monitoring station features a three-position control switch used in dynamic smoke management systems for fire and smoke dampers.

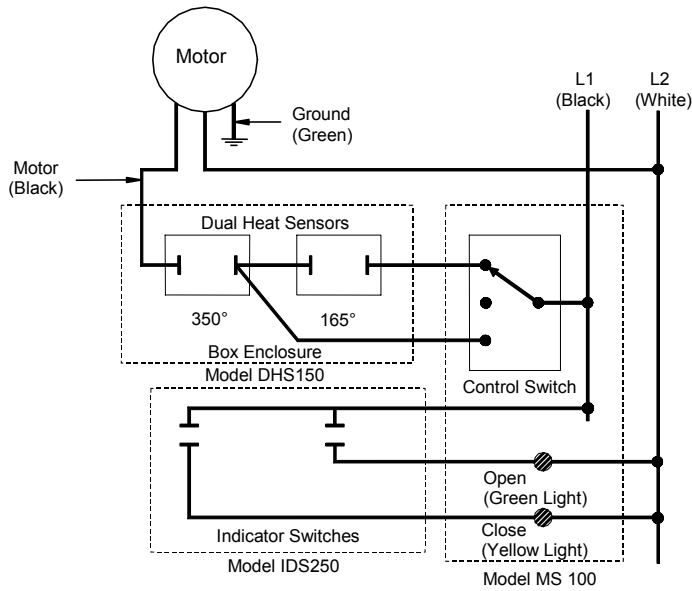

**WIRING DIAGRAM FOR DUAL HEAT SENSORS AND INDICATOR SWITCH**

**Model MS100 Monitoring Station**

This is a toggle switch with indicator lights that provides a quick and easy method to activate the damper from open to close to test the function. Comes optional with a "removable" key type switch and can be mounted remotely or on the damper.

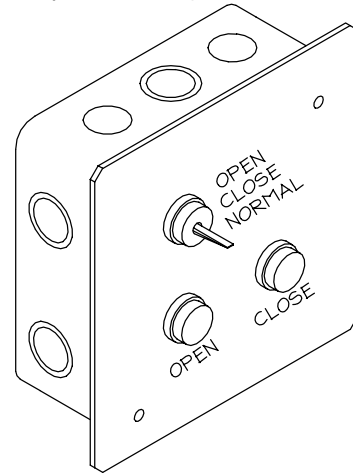

**Model MS100 Monitoring Station**

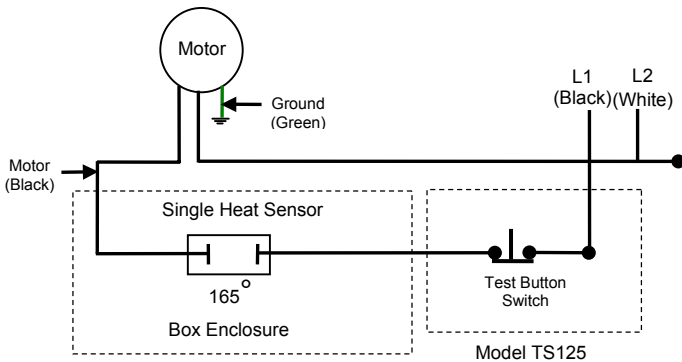

**WIRING DIAGRAM FOR SINGLE HEAT SENSOR AND TEST STATION**

**Model TS125 Test Station**

A push button for momentary checking of damper function. When the button is pushed the damper will close and reopen when the button is released. This should be mounted on the damper.

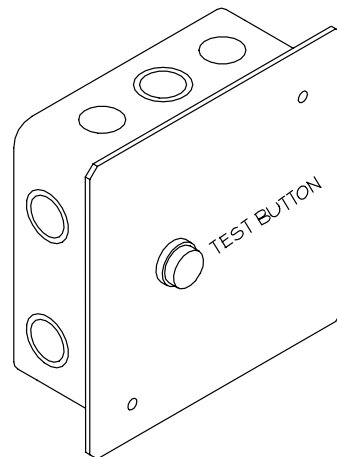

**Model TS125 Test Station**

DATE	ARCHITECT / ENGINEER			CUSTOMER
PROJECT				
ITEM	QTY	W	H	DESCRIPTION