

**Static Integral Sleeve Curtain Fire Damper Model – 150-12A, 14A, 16A**

**Features** – U.L. rated 1 ½ hour fire damper, for use in a 2 hour fire partition. • Meets NFPA 90A & UL 555 • Meets California State Fire Marshal Requirements.

**STANDARD CONSTRUCTION**

**FRAME AND SLEEVE**

- 150-12A 12" x 20 gauge galvanized steel
- 150-14A 14" x 20 gauge galvanized steel
- 150-16A 16" x 20 gauge galvanized steel

**BLADES**

- 3-3/8" wide 22 gauge galvanized steel

**MAXIMUM SINGLE SECTION**

- Vertical: 48" w x 48" h
- Horizontal: 48" w x 48" h

**MINIMUM SIZE**

- Vertical: 6" w x 6" h
- Horizontal: 6" w x 6" h

**UNDERSIZED**

- 1/4" undersize unless specified otherwise

**FUSIBLE LINK**

- 165°F standard (others available)

**SPRINGS**

- Stainless steel – 301 Negator type
- (Standard on Horizontal mount only)

**OPTIONAL CONSTRUCTION**

- RETAINING ANGLES** – Shipped Loose
- SECURITY BARS** – Mounted in sleeve
- FUSIBLE LINK** – Electronically triggered link (ETL)

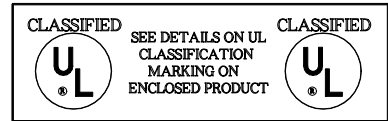

Damper is a rollformed 20 ga. steel frame and sleeve combination

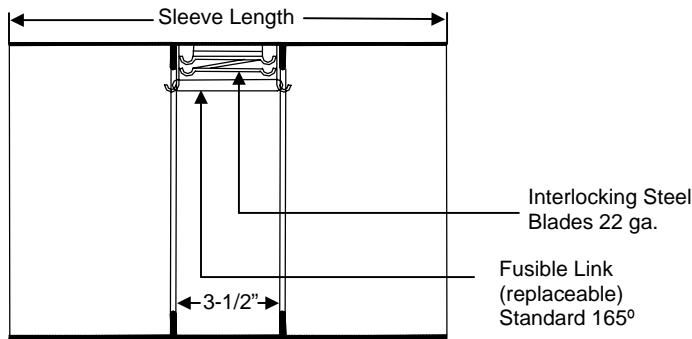
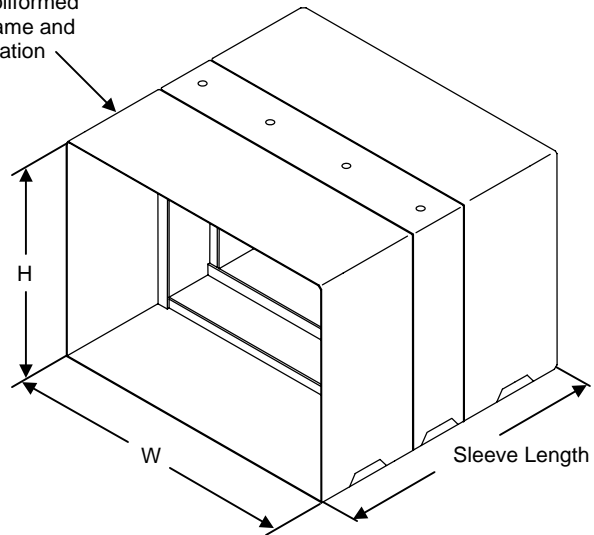

**Vertical Section**

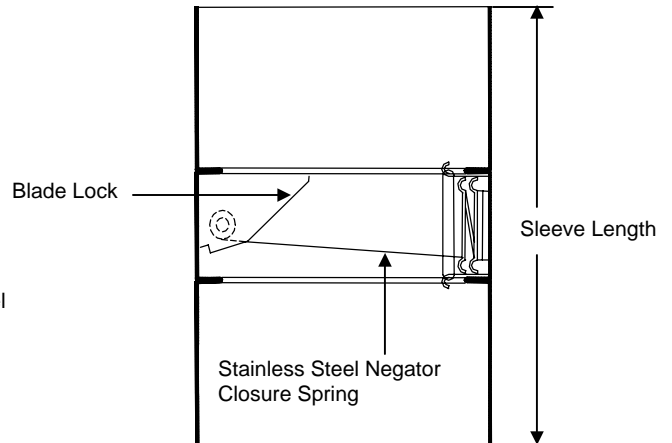

**Horizontal Section**

|         |           |   |   |             |
|---------|-----------|---|---|-------------|
| DATE    | ARCHITECT |   |   | ENGINEER    |
| PROJECT |           |   |   |             |
| ITEM    | QTY       | W | H | DESCRIPTION |
|         |           |   |   |             |
|         |           |   |   |             |
|         |           |   |   |             |
|         |           |   |   |             |
|         |           |   |   |             |



DEPENDABLE PRODUCTS SINCE 1955

**SAFE-AIR OF ILLINOIS, INC.**

*Engineering and General Offices*  
 1855 South 54th Avenue, Cicero, Illinois 60804  
 Phone 708-652-9100 FAX 708-652-9158