

Static Integral Sleeve Curtain Fire Damper Model – 150-12CRD, 14CRD, 16CRD

Features – U.L. rated 1 ½ hour fire damper, for use in a 2 hour fire partition. Meets NFPA 90A & UL 555 Meets California State Fire Marshal Requirements.

STANDARD CONSTRUCTION

FRAME AND SLEEVE

- 150-12CRD 12" x 20 gauge galvanized steel
- 150-14CRD 14" x 20 gauge galvanized steel
- 150-16CRD 16" x 20 gauge galvanized steel

BLADES

- 3-3/8" wide 22 gauge galvanized steel

MAXIMUM SINGLE SECTION

- 42" Diameter

MINIMUM SIZE

- 4" Diameter

UNDERSIZED

- ¼" (6) undersize unless specified otherwise

FUSIBLE LINK

- 165° (73°)C standard (others available)

SPRINGS

- Stainless steel – 301 Negator type
(Standard on Horizontal mount only)

OPTIONAL CONSTRUCTION

WELDED CONSTRUCTION

"D" STYLE – Low Pressure applications

RETAINING ANGLES – Shipped Loose

SECURITY BARS – Mounted in sleeve

FUSIBLE LINK – Electronically triggered link (ETL)

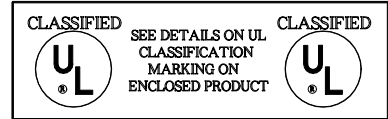

Damper is a rollformed 20 ga. steel frame and sleeve combination

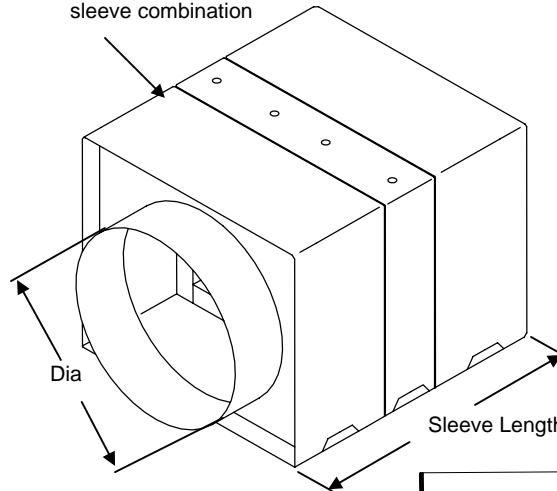

Duct Height	Dim. (X)
4" thru 15"	2"
16" thru 27"	3"
28" thru 39"	4"
40" thru 55"	5"
40" thru 43" (Horizontal Only)	

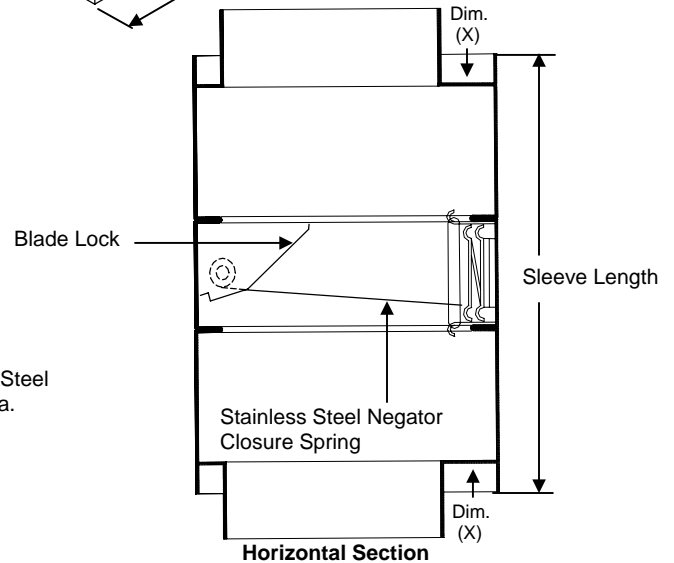
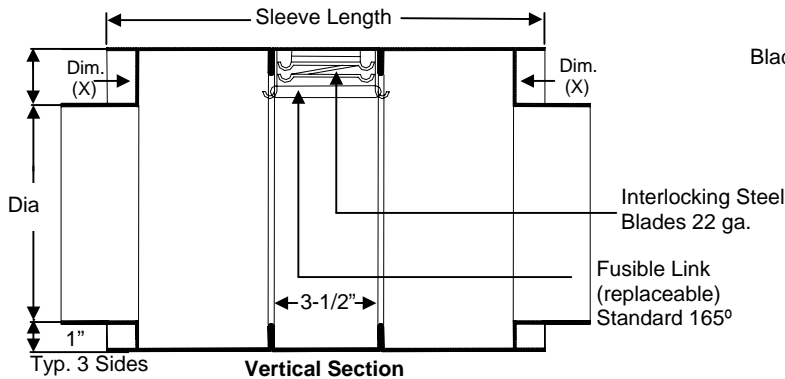

DATE	ARCHITECT			ENGINEER
PROJECT				
ITEM	QTY	W	H	DESCRIPTION



DEPENDABLE PRODUCTS SINCE 1955

SAFE-AIR OF ILLINOIS, INC.

Engineering and General Offices
1855 South 54th Avenue, Cicero, Illinois 60804
Phone 708-652-9100 FAX 708-652-9158