

Blade Fire Damper Model D - 175 / series Masonry or Concrete Wall Installation Instructions

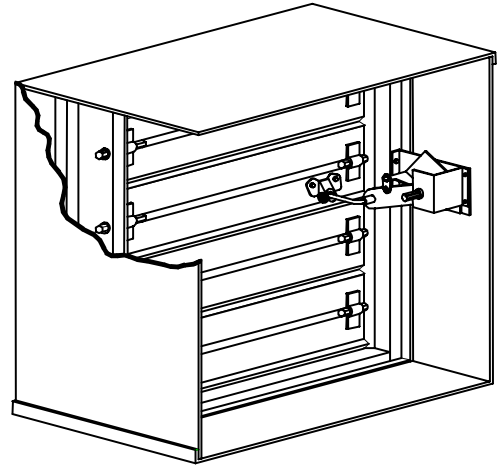
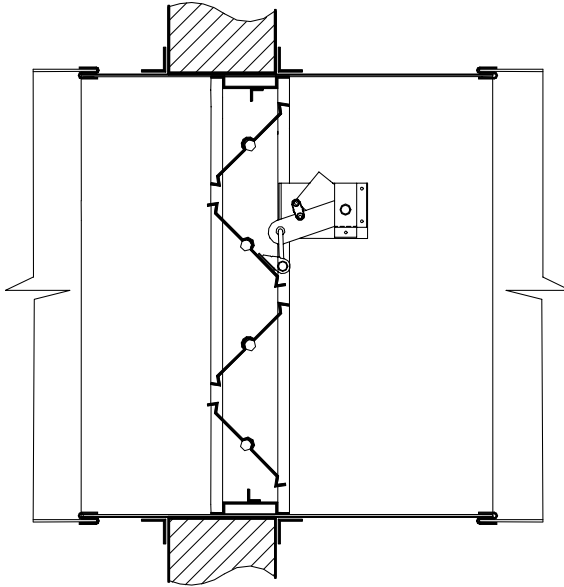

1. Angles: 1-1/2" x 18ga. Typical. Fasten to sleeve with 1/4" diameter nuts and bolts, 3/16" steel pop rivets, or welding. All fastenings to be 8" on centers on all four sides. Angles are not fastened at corners. *Note: Angles must overlap the wall a minimum of 1", - increase the angle size if necessary.
2. Duct run shall terminate at sleeve or frame of damper. Secure damper to sleeve with 1/4" diameter nuts and bolts, #10 sheet metal screws, 3/16" pop rivets, or welding. All fastenings to be on 8" centers.
3. Clearance requirements between sleeve and wall or floor shall be minimum of 1/8" per foot of width and height of sleeve. The maximum size of opening shall be 2" larger in width or height than the allowed minimum size.
4. The following duct collar connections may be on all systems:

◆ Inside Slip	◆ Angle Slip
◆ Plain "S" Slip	◆ Double "S" Slip
◆ Hemmed "S" Slip	◆ Cup Slip
◆ Bar Slip	◆ Drive Slip
◆ Alternate Bar Slip	◆ Pocket Slip
5. The sleeve gauge shall be at least equal to the gauge of the duct, as specified by SMACNA duct connection standards and NFPA 90A, when one or more of the above sleeve connections are used. If other duct connections are used, the sleeve shall be a minimum of 16ga. for dampers up to 36" W x 24"H and 14ga. for dampers over 36"W x 24"H. (See SMACNA Fire Damper instruction guide book). If sleeves are field supplied, they shall be 10 to 24-gauge steel. The inner dimensions of the sleeve are to be equal to the outer dimensions of the damper. The length of the sleeve or the duct collar extends beyond the wall, shall not exceed 6 inches on either side, or 16 inches on the side supplied with an access door.
6. Minimum and Maximum Size UL classified:

Minimum size: 8" W x 6" H (203 x 152)
Maximum size: Static system: 36" W x 48" H (914 x 1219)
Dynamic system: 36" W x 36" H (914 x 914)