

**Corridor Fire/Smoke Combination Damper – Model 472 CLASS II**

**Features** – U.L. rated for dynamic closure & leakage CLASS II @ 250° F or 350° F. Meets NFPA 90A & UL 555 & UL 555S. Seismic and Fragility tested. Meets California State Fire Marshal Requirements.

**STANDARD CONSTRUCTION**

**FRAME**

4-5/16" deep, 16 gauge galvanized steel

**BLADES**

6 1/2" wide, 16 gauge galvanized steel  
(Bottom blade width may vary depending on damper height)

**BLADE AXLES & BEARINGS**

AXLES – 7/16" Dia. Plated hex mechanically fastened to blade  
BEARINGS – 1/2" Dia. Bronze oil impregnated

**LINKAGE**

Plated steel in opposed blade configuration, concealed inside the jamb

**SEALS**

Silicone blade edge and stainless steel jamb seals

**MAXIMUM UL CLASSIFIED LEAKAGE CLASS II SIZE**

24" W x 24"H

**MINIMUM UL CLASSIFIED LEAKAGE CLASS II SIZE**

12"W x 9"H

**SLEEVE**

18 ga. x 16" deep galvanized steel

**UNDERSIZED**

1/4" under ordered size unless specified Exact or Actual

**FINISH**

Mill

**HEAT SENSOR**

120 VAC, 165° to 350°

**OPERATOR**

Refer to UL approved actuator chart

**MOUNTING ANGLES**

1-1/2" x 1-1/2" x 18 ga. galvanized steel

**OPTIONAL CONSTRUCTION**

**SLEEVE AND DUCTWORK CONNECTION** – 10 ga. to 20 ga. galvanized steel to 30" in length. – Transitions available in: round, oval, rectangular or custom. Factory can install access door, retaining angles, or flange connections.

\*Dampers 11" high and under will be single blade, and extend from the frame proportionately

**ACCESSORIES**

Smoke Detector  
Indicator Switches  
Monitoring Station  
Dual Sensors



03225-0751-104

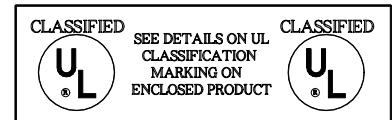

Internal Motor Mount Only

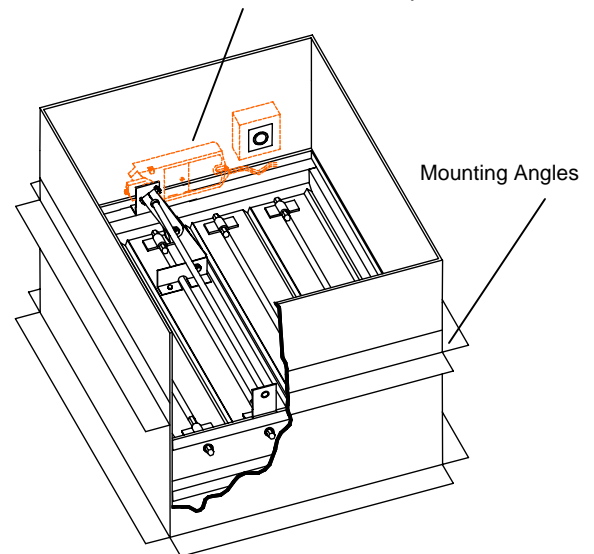

**APPROVED ACTUATORS**

**Honeywell Siemens Belimo**

|             | Honeywell | Siemens   | Belimo      |
|-------------|-----------|-----------|-------------|
| 24 Vac -    | ML 8115   | GND121.1U | FSNF24 US*  |
|             | MS 820    | GND126.1U |             |
|             | MS 8120   | GGD121.1U |             |
| 120 Vac -   | ML 4115   | GND221.1U | FSNF120 US* |
|             | MS 4209   | GND226.1U |             |
|             | MS 4120   | GGD221.1U |             |
| 230 Vac -   |           | GND321.1U |             |
|             |           | GGD321.1U |             |
| Pneumatic - |           | 331-2961  |             |
|             |           | 331-3060  |             |
|             |           | 331-4826  |             |

\* Only for dampers up to 24" x 24"

|         |           |   |   |             |          |
|---------|-----------|---|---|-------------|----------|
| DATE    | ARCHITECT |   |   |             | ENGINEER |
| PROJECT |           |   |   |             |          |
| ITEM    | QTY       | W | H | DESCRIPTION |          |
|         |           |   |   |             |          |
|         |           |   |   |             |          |
|         |           |   |   |             |          |
|         |           |   |   |             |          |
|         |           |   |   |             |          |



DEPENDABLE PRODUCTS SINCE 1955

**SAFE-AIR/DOWCO**

Engineering and General Offices

1855 South 54th Avenue, Cicero, Illinois 60804

Phone 708-652-9100 FAX 708-652-9158

**AIR PERFORMANCE**

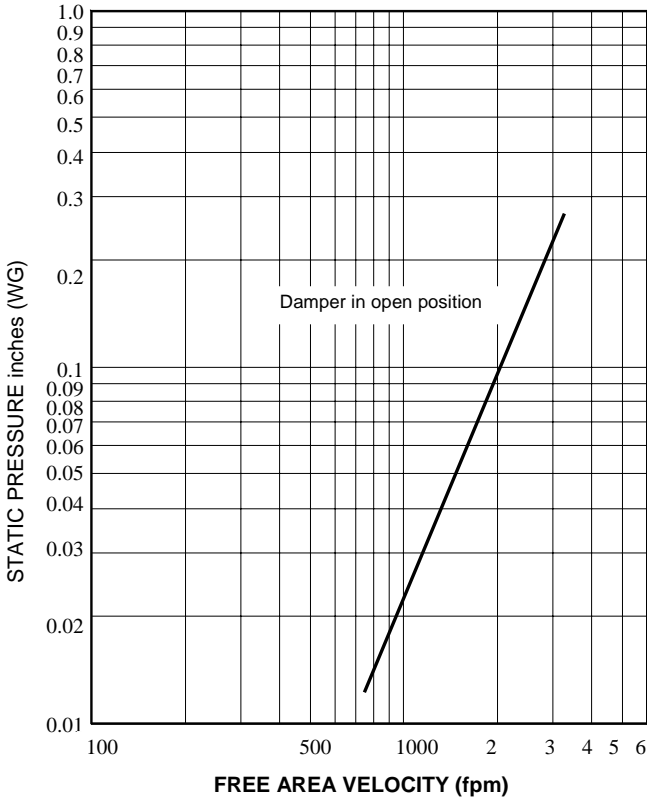

**AIR LEAKAGE**

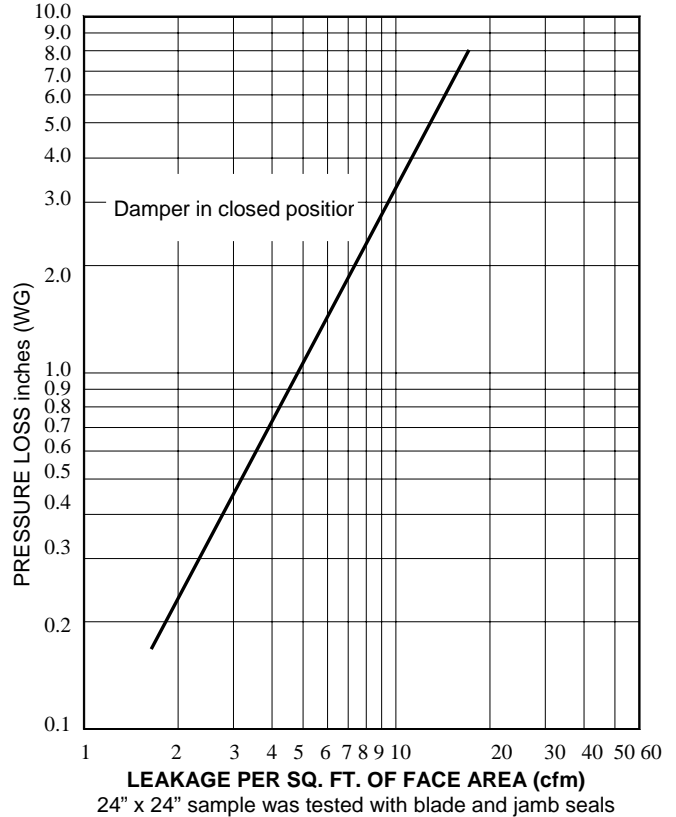

24" x 24" sample was tested with blade and jamb seals

**CALCULATING PRESSURE LOSS:**

Based upon a given flow rate (in CFM), the flowing pressure loss may be determined from the "air performance graph, knowing the sq. ft. of free area of the damper. Alternately, the free area may be determined based upon a volumetric flow rate and a maximum pressure loss. Utilizing the "air performance" graph.

\_\_\_\_\_ in. W.C. Max. Pressure Loss Intake or Exhaust

\_\_\_\_\_ FPM (Free Area Velocity From "Air Performance" Graph)

\_\_\_\_\_ CFM / \_\_\_\_\_ FPM Free Area Velocity = \_\_\_\_\_ Sq. Ft. Free Area

**U. L. CLASSIFIED DYNAMIC CLOSURE RATING**

Our maximum recommended operating for this damper is 2000 fpm @ 4" static pressure. This damper has been tested in accordance with the U.L. requirements for closure under installed " system in operation " conditions, (Dynamic closure). Single sections 24"w x 24"h have been tested capable to close, mounted either vertical or horizontal, at 3000 fpm. @ 8" static pressure.

**FREE AREA CALCULATIONS IN SQ. FT.**

|        |        | WIDTH |      |      |      |
|--------|--------|-------|------|------|------|
|        |        | 12    | 16   | 20   | 24   |
| HEIGHT | Inches | 12    | 16   | 20   | 24   |
|        | 12     | 0.56  | 0.78 | 1.00 | 1.22 |
|        | 16     | 0.83  | 1.17 | 1.50 | 1.83 |
|        | 20     | 1.06  | 1.48 | 1.91 | 2.33 |
| 24     | 1.28   | 1.80  | 2.31 | 2.83 |      |