

**CONTROL DAMPER - MODEL 610 / 611**

**Design Features** – Nested closure “V” blade design that provides a greater sealing surface than competitive designs.

**STANDARD CONSTRUCTION**

**FRAME**

4-5/16" deep, 16 gauge galvanized steel

**BLADES**

6" wide, 16 gauge galvanized steel  
(Bottom blade width may vary depending on damper height)

**BLADE AXLES & BEARINGS**

AXLE – 7/16" Plated hex  
BEARING – Bronze oil impregnated

**LINKAGE**

610 - Plated steel concealed inside of jamb  
611 – Plated steel mounted mid span of blade  
Drive blade has a 1" to 6" extendable shaft to mount operator

**MAXIMUM SIZE**

Unlimited, with mullions, structural bracing supplied by others  
(Multi-section sizes usually require jackshaftering)

**MAXIMUM SINGLE SECTION**

48"W x 72"H

**MINIMUM SIZE**

4"W x 4"H\*

**SEALS**

Optional

**UNDERSIZED**

1/4" under ordered size unless specified Exact or Actual

**FINISH**

Mill

**OPERATOR**

None

Model 610  
Opposed Blade

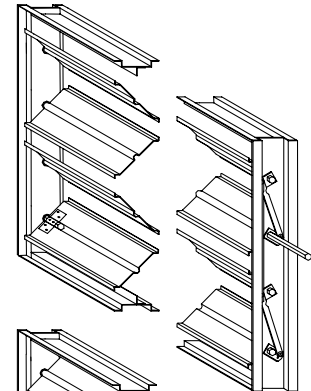

Model 611  
Parallel Blade

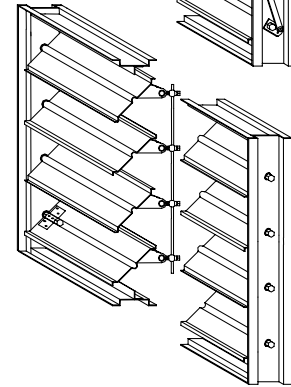

**OPTIONAL CONSTRUCTION**

**FRAME** – Available in heavier galvanized construction up to 10 gauge

**BLADES** – Available in heavier galvanized construction up to 10 gauge

**SPECIFIED MATERIAL** – Available in stainless, Aluminum or as requested

**LINKAGE** – Mounted on face of blades in either opposed or parallel

**BLADE & JAMB SEALS** – Silicone blade edge and/or stainless steel jamb seals

**SLEEVE AND DUCTWORK CONNECTION** – 10 ga. to 20 ga. galvanized steel to 30" in length. – Transitions available in: round, oval, rectangular or custom. Factory can install access door, retaining angles, or flange connections.

**FINISH** – Air-dry primer, polyurethane, epoxy, or enamel, Baked epoxy or enamel, or Powder coat.

**OPERATOR** – Manual, electric or pneumatic, internally or externally mounted, please consult operator listing

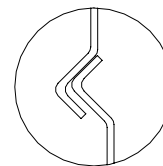

Blades closed  
without seal

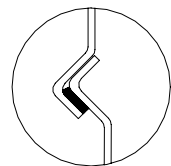

Blades closed  
with seal  
(optional)

**SPECIAL PURPOSE CONSTRUCTION**

- Fully welded corner assembly
- Security bars (mounted in sleeve)
- Filter racks
- Face and bypass dual mixing damper configuration

\* Dampers 11" high an under will be single blade, and extend from the frame proportionately.

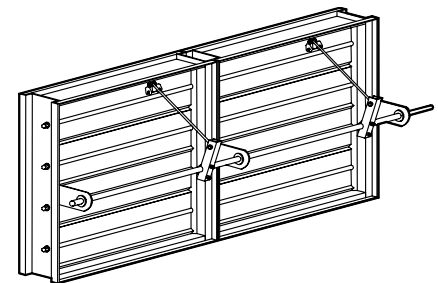

Typical jackshaftered multiple section assembly

DATE	ARCHITECT / ENGINEER			CUSTOMER
PROJECT				
ITEM	QTY	W	H	DESCRIPTION

### AIR PERFORMANCE

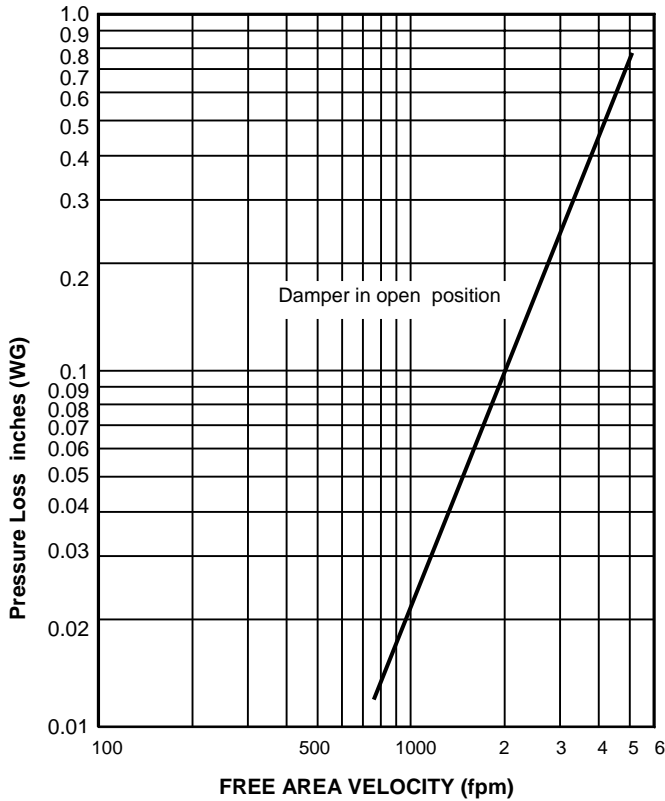

### AIR LEAKAGE

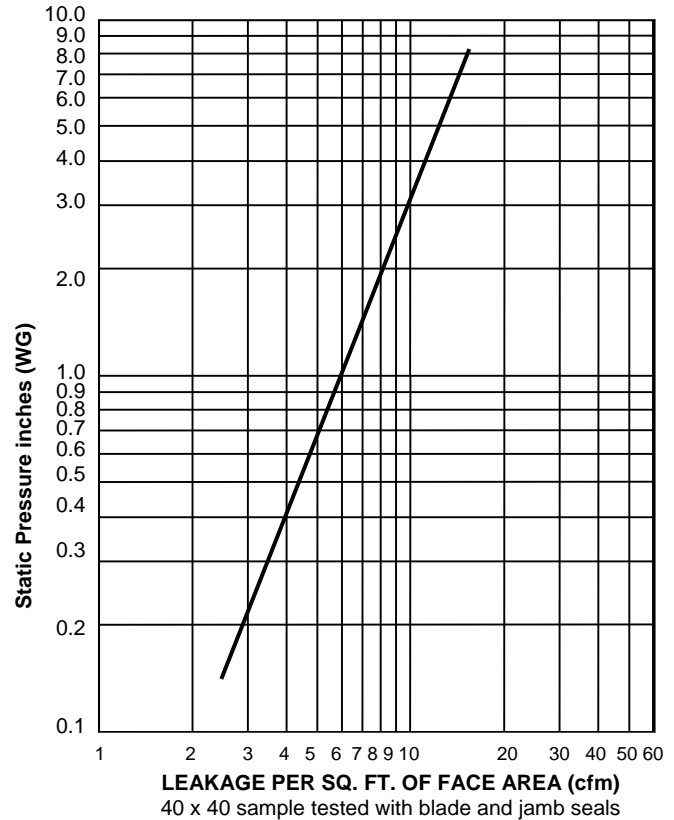

#### CALCULATING PRESSURE LOSS:

Based upon a given flow rate (in CFM), the flowing pressure loss may be determined from the "air performance graph, knowing the sq. ft. of free area of the damper. Alternately, the free area may be determined based upon a volumetric flow rate and a maximum pressure loss. Utilizing the "air performance" graph.

\_\_\_\_\_ in. W.C. Max. Pressure Loss Intake or Exhaust  
 \_\_\_\_\_ FPM (Free Area Velocity From "Air Performance" Graph)  
 \_\_\_\_\_ CFM / \_\_\_\_\_ FPM Free Area Velocity = \_\_\_\_\_ Sq. Ft. Free Area

Damper Width Inches	Maximum Static Pressure (W.G.)	Maximum Velocity	Leakage W/Seals	Leakage W/ Out Seals
12	5"	1500 FPM	14	55
18	4.5"	1500 FPM	13	51
24	4"	1500 FPM	12	47
30	3.5"	1500 FPM	11	43
36	3"	1500 FPM	10	40
42	2.5"	1500 FPM	9	36
48	2"	1500 FPM	8	32

#### FREE AREA CALCULATIONS IN SQ. FT.

H E I G H T	W I D T H										
	Inches	12	16	20	24	28	32	36	40	44	48
12	0.58	0.81	1.03	1.26	1.49	1.72	1.95	2.17	2.40	2.63	
16	0.86	1.20	1.54	1.88	2.22	2.56	2.89	3.23	3.57	3.91	
20	1.09	1.53	1.96	2.39	2.82	3.26	3.69	4.12	4.55	4.99	
24	1.33	1.86	2.38	2.91	3.43	3.96	4.49	5.01	5.54	6.06	
28	1.61	2.25	2.89	3.52	4.16	4.80	5.43	6.07	6.71	7.34	
32	1.85	2.58	3.31	4.04	4.77	5.50	6.23	6.96	7.69	8.42	
36	2.08	2.91	3.73	4.55	5.38	6.20	7.02	7.85	8.67	9.49	
40	2.37	3.30	4.23	5.17	6.10	7.04	7.97	8.91	9.84	10.78	
44	2.60	3.63	4.66	5.68	6.71	7.74	8.77	9.80	10.82	11.85	
48	2.84	3.96	5.08	6.20	7.32	8.44	9.56	10.69	11.81	12.93	
52	3.29	4.60	5.90	7.20	8.50	9.80	11.10	12.41	13.71	15.01	
56	3.36	4.68	6.01	7.33	8.66	9.98	11.31	12.63	13.96	15.29	
60	3.59	5.01	6.43	7.85	9.27	10.68	12.10	13.52	14.94	16.36	
64	3.87	5.40	6.93	8.46	9.99	11.52	13.05	14.58	16.11	17.64	
68	4.11	5.73	7.35	8.98	10.60	12.22	13.85	15.47	17.09	18.72	
72	4.34	6.06	7.78	9.49	11.21	12.93	14.64	16.36	18.08	19.79	