

**FIRE / SMOKE DAMPER MODELS -771 & 772 OP
MASONRY, CONCRETE, WOOD AND STEEL STUD/GYPSUM WALLBOARD INSTALLATION
INSTRUCTIONS**

Supplemental Instructions refer also to model 771/772 basic installation instructions.

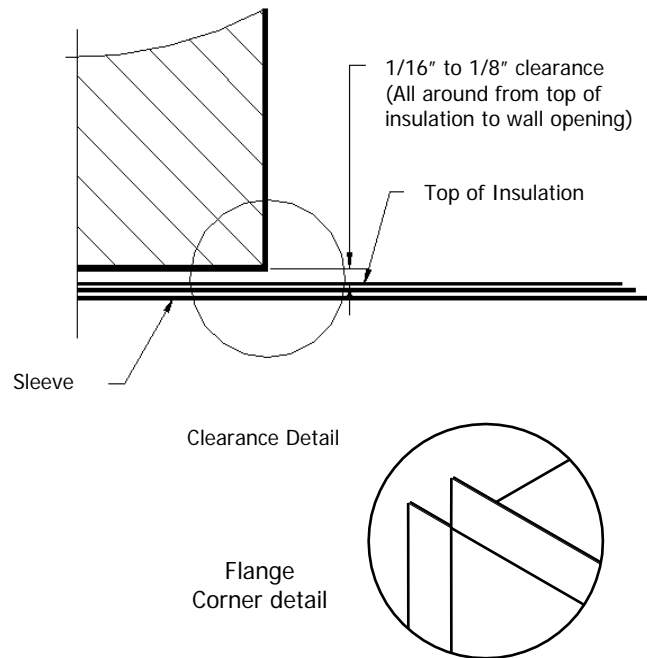
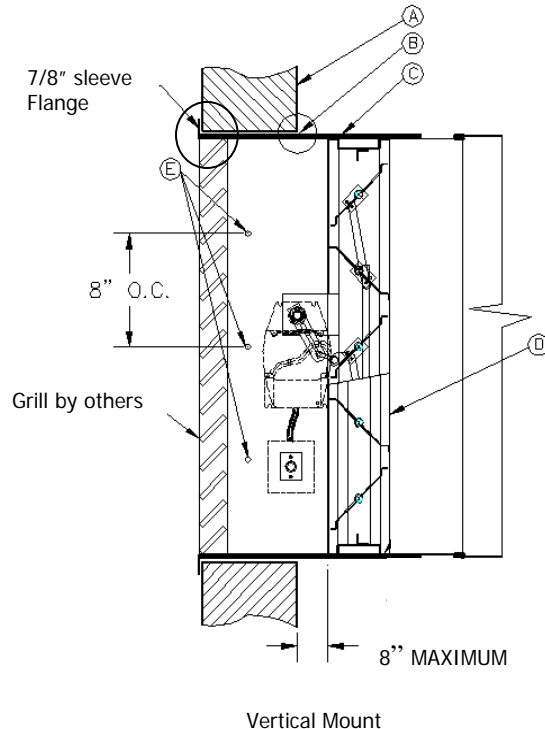

Typical Installation Details

- (A) Wall Opening refer to framing instructions for damper installed in gypsum board partitions
- (B) Clearance: 1/8" – 1/4" larger than overall outside dimensions of sleeve including insulation.
- (C) Steel sleeve factory provided covered with factory provided insulation.
- (D) Fire Damper 771 & 772 OP
- (E) Sleeve shall be secured to inside perimeter of wall opening as follows:
Masonry / Concrete Wall - Min. 3/16" diameter, 1-1/2" long steel concrete anchors w/screws, or self-tapping masonry screws. Fasteners 8" OC, 2" max. from each corner.
Steel Stud / Gypsum Board Partition - Min. No. 10 steel screws be 1-1/4" long. Fasteners located 8" OC, 2" max. from each corners.

Notes:

1. Maximum distance out of wall for damper is to be no greater than 8." This distance is measured from the rear of the damper to the exposed wall face.
2. 1/4" Insulation consist of (2) layers of factory installed 1/8" thick insulation.

Installation – Failure to follow these instructions will void all warranties.

These instructions apply to 1 1/2" hour rated combination fire smoke dampers mounted (blades must be horizontal) in: 1) masonry, block or stud walls. Specific requirements in these instructions are mandatory. Dampers must be installed in accordance with these instructions to meet the requirements of UL 555 and UL 555S. The installation of the damper and all duct connections to the damper sleeve shall conform to the latest editions of NFPA 90A, Standard for the installation of Air Conditioning and Ventilating Systems, and the SMACNA Fire, Smoke and Radiation damper installation guide, and U.L. Classifications R7861.

Clearances Required between Fire Damper Sleeves and Wall/Floor Openings.

Fire damper and sleeve assemblies expand during periods of intense heat. Therefore, it is essential that openings in walls be larger than the fire/smoke damper and sleeve assembly to allow for this expansion. Clearance requirements between sleeve and wall or floor shall be minimum of 1/8 per foot of width and height of sleeve. The maximum size of opening shall be 2" larger in width or height than the allowed minimum size, see clearance detail shown above.