

## Industrial Control Dampers – Models ARO-3 & ARM-3

**Design Features** – Galvanized Steel Industrial Control Damper with corrugated V-blade design for low-pressure drop and high static pressure applications in industrial systems.

### STANDARD CONSTRUCTION

**FRAME**

8" x 2" x 14 gauge galvanized steel channel to 1/4" steel channel

**BLADES**

5" to 8" wide, 16 gauge galvanized steel to 1/4" thk.

**ARO** – Opposed Blade

**ARM** – Parallel Blade

**BLADE AXLES & BEARINGS**

AXLE – 1/2" to 1" dia.

BEARING – Sleeve press-fit

**LINKAGE**

Plated steel linkage concealed in channel (standard construction)

**MAXIMUM SIZE**

Unlimited, with mullions, structural bracing supplied by others

**MAXIMUM SINGLE SECTION**

48" W x 96" H (I.D)

**MINIMUM SIZE**

6" W x 6" H (I.D)

**MAXIMUM TEMPERATURE**

250 Deg. Fahrenheit

**FINISH**

Mill Finish

**OPERATOR**

None

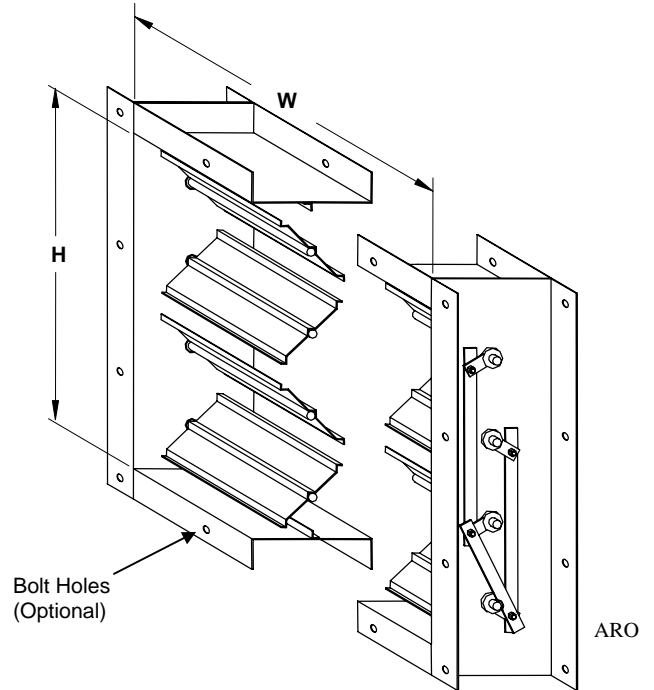

### OPTIONAL CONSTRUCTION

**SPECIFIED MATERIAL** – Available in stainless steel

**BLADE AXLES & BEARINGS** – 1-1/2" to 2" dia

**SLEEVE AND DUCTWORK CONNECTION** – 10 ga. to 16 ga. galvanized steel to 30" in length. – Transitions available in: round, oval, rectangular or custom. Factory can install access door, retaining angles, or flange connections.

**FINISH** – Air-dry primer, polyurethane, epoxy, or enamel, Baked epoxy or special finishes available

**OPERATOR** – Manual, electric or pneumatic, please consult operator listing. (Operator type and location will affect the temperature rating of the damper)

**SEALS** – Silicone Blade seals and Stainless Steel jamb seals available

**BOLT HOLES** – Bolt Holes in flange available

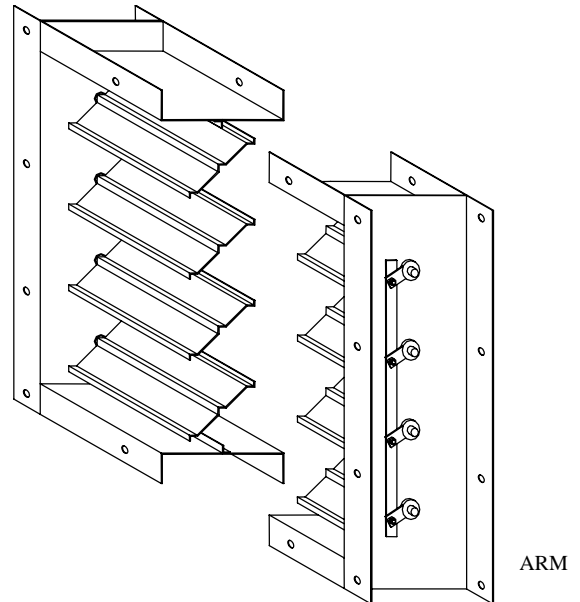

DATE	ARCHITECT			CUSTOMER
PROJECT				
ITEM	QTY	W	H	DESCRIPTION

