

Combination Fixed / Adjustable Dual Drainable Blade Louver Model C-DDE-46

Design Features – Combination feature gives a hidden effect and superior shut off quality to competitive designs. Useful applications are high static pressure systems or where tightest possible seal is required.

STANDARD CONSTRUCTION

ALL MATERIAL – EXTRUDED ALUMINUM 6063-T5 (KB-45)

FRAME

6" (152) Deep, .081" (2.1) extruded aluminum in style #3

BLADES

Fixed - Dual drainable design .081" (2.1) extruded aluminum @ 5-1/2" (140) @ 39°
Adjustable - .125" thk. (3.2) extruded aluminum

BLADE AXLES & BEARINGS

Axles – 7/16" (11) plated steel hex
Bearings –Bronze oilite

LINKAGE

Plated steel concealed in jamb

BLADE & JAMB SEALS

Vinyl blade edge and flexible aluminum jamb seals

MAXIMUM SIZE

Unlimited, with mullions, structural bracing supplied by others

MAXIMUM SINGLE SECTION

60" W x 96"H (1524 X 2438) (Over 60" (1524) wide will have double linkage)

MULLION

Visible

MINIMUM SIZE

12"w x 12"h (305 X 305)

UNDERSIZED

1/4" (6) under ordered size unless specified Exact or Actual

SCREEN

3/4" x .051" (19 X 1.3) flattened expanded aluminum bird screen in frame

FINISH

Mill

OPERATOR

Wing-nut adjustable

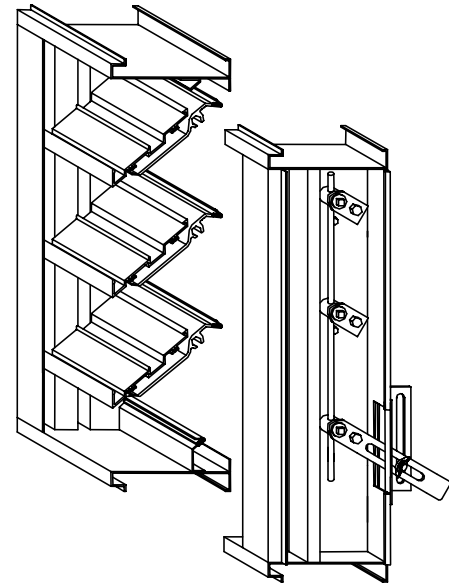

MULLION STYLE

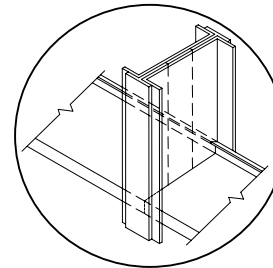

Visible

PERFORMANCE
Point of water penetration
929 fpm
Free area
<u>48 x 48 section</u>
49%

OPTIONAL CONSTRUCTION

FRAME – Available in a heavier extrusion of .125" (3.2)

BLADES - Available in a heavier extrusion of .125" (3.2)

JAMB SEALS – Stainless steel jamb seals

SCREEN - Many styles available please consult screen listing

FINISH – Air-dry primer, polyurethane, epoxy, or enamel, baked epoxy or enamel, Anodize or Kynar.

OPERATOR – Manual, Electric or Pneumatic

SPECIAL PURPOSE CONSTRUCTION

- Welded linkage
- Security bars
- Filter racks
- Sleeved for ductwork connection
- Jackshaft when required

** Consult SAFE-AIR/DOWCO for additional technical information.

TYPICAL SCREEN STYLES

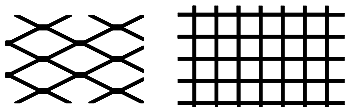

Expanded Aluminum Standard

Wire Mesh

FRAME STYLES

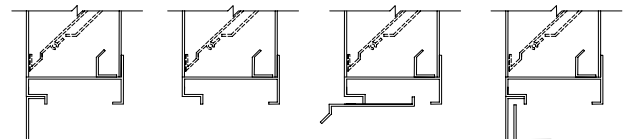

(1) - Flange 1-1/2"

(3) - Box Standard

(8) - Box and Sill Extension

(9) - Flange w/ sub frame

DATE	ARCHITECT			CUSTOMER
PROJECT				
ITEM	QTY	W	H	DESCRIPTION



DEPENDABLE PRODUCTS SINCE 1955

SAFE-AIR OF ILLINOIS INC.

Engineering and General Offices

1855 South 54th Avenue, Cicero, Illinois 60804

Phone 708-652-9100 FAX 708-652-9158

All tests performed at an independent laboratory and based on AMCA standard 511 – 91 for air performance and water penetration.

AIR PERFORMANCE

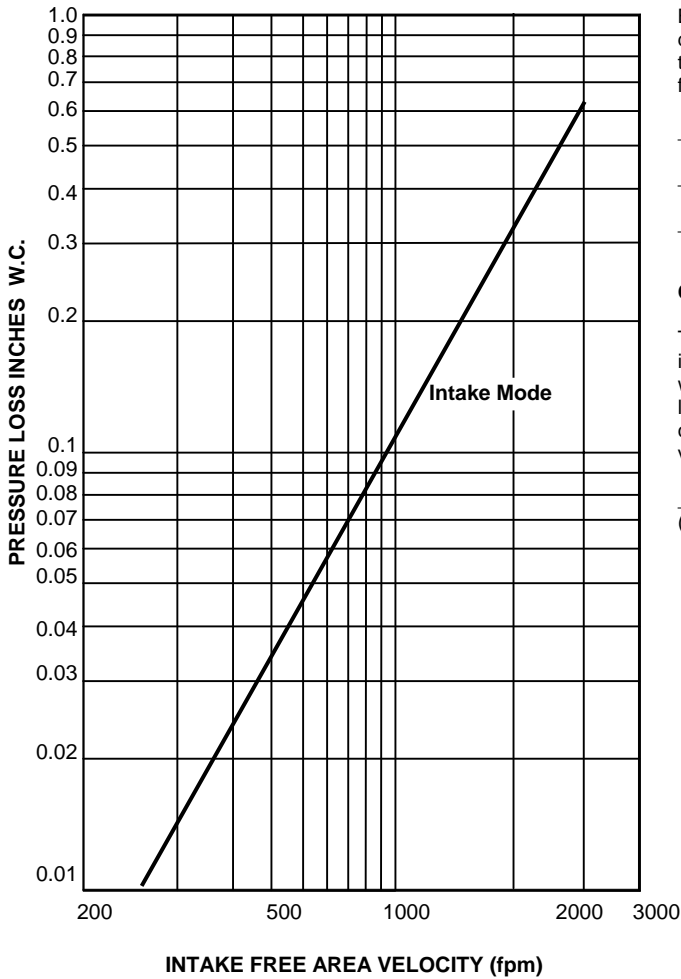

CALCULATING PRESSURE LOSS

Based upon a given flow rate (in CFM), the flowing pressure loss may be determined from the "air performance" graph, knowing the sq. ft. of free area of the louver. Alternately, the free area may be determined based upon a volumetric flow rate and a maximum pressure loss. Utilizing the "air performance" graph.

_____ in. W.C. Max. Pressure Loss Intake or Exhaust
 _____ FPM (Free Area Velocity From "Air Performance" Graph)
 _____ CFM / _____ FPM Free Area Velocity = _____ Sq. Ft. Free Area

CALCULATING MAXIMUM AIRFLOW BEFORE WATER PENETRATION

The "free area flow rate" at which water penetration commences (.01 oz. of water) is established at, 929 fpm for C-DDE-46, and will vary depending upon actual weather conditions. The "water penetration" graph illustrates the results of actual laboratory test on a 48" x 48" test sample subjected to hypothetical rainfall conditions. To determine the free area (in sq. ft.) based on upon a known volumetric flow rate in CFM;

_____ CFM / _____ FPM = _____ SQ. FT. FREE AREA
 (System Requirements)

Water Penetration Graph

in oz. of water per sq. ft. of free area over a 15 min. test period

	.01	.02	.05	.1	.2	.3 (H2O)
	929	967	1017	1055	1093	1115 (fpm)

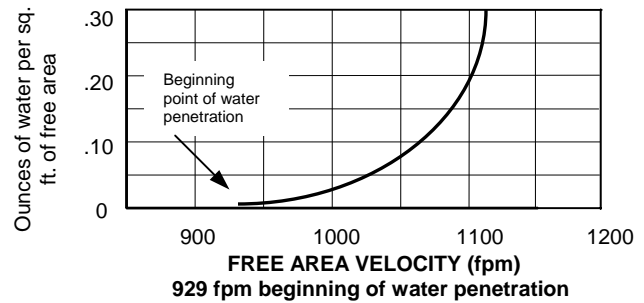

FREE AREA CALCULATIONS IN SQ. FT.

WIDTH

HEIGHT	WIDTH									
	Inches	12	18	24	30	36	42	48	54	60
12		0.19	0.33	0.47	0.61	0.74	0.88	1.02	1.16	1.29
18		0.41	0.70	0.99	1.28	1.57	1.86	2.15	2.45	2.74
24		0.63	1.07	1.52	1.96	2.40	2.85	3.29	3.73	4.18
30		0.85	1.44	2.04	2.64	3.23	3.83	4.43	5.02	5.62
36		1.06	1.81	2.56	3.31	4.06	4.81	5.56	6.31	7.06
42		1.28	2.18	3.09	3.99	4.89	5.79	6.70	7.60	8.50
48		1.50	2.55	3.61	4.66	5.72	6.78	7.83	8.89	9.95
54		1.71	2.92	4.13	5.34	6.55	7.76	8.97	10.18	11.39
60		1.93	3.29	4.65	6.02	7.38	8.74	10.10	11.47	12.83
66		2.15	3.66	5.18	6.69	8.21	9.72	11.24	12.76	14.27
72		2.36	4.03	5.70	7.37	9.04	10.71	12.38	14.04	15.71
78		2.58	4.40	6.22	8.05	9.87	11.69	13.51	15.33	17.15
84		2.80	4.77	6.75	8.72	10.70	12.67	14.65	16.62	18.60
90		3.01	5.14	7.27	9.40	11.53	13.65	15.78	17.91	20.04
96		3.23	5.51	7.79	10.07	12.36	14.64	16.92	19.20	21.48