

Combination Fixed / Adjustable Blade Louver Model C-LEC-46

Design Features – Combination feature gives a hidden effect and superior shut off quality to competitive designs. Useful applications are high static pressure systems or where the tightest possible seal is required.

STANDARD CONSTRUCTION

ALL MATERIAL – EXTRUDED ALUMINUM 6063-T5 (KB-45)

FRAME

6" Deep, .081" extruded aluminum in style #3

BLADES

Fixed - Drainable .081" extruded aluminum 5-1/2" @ 45°

Adjustable - .125" thk. extruded aluminum

BLADE AXLES & BEARINGS

Axles – 7/16" plated steel hex

Bearings – bronze oilite

LINKAGE

Plated steel concealed in jamb

BLADE & JAMB SEALS

Vinyl blade and flexible aluminum jamb seals

MAXIMUM SIZE

Unlimited, with mullions, structural bracing supplied by others

MAXIMUM SINGLE SECTION

60" W x 96"H (Over 60" wide will have double linkage)

MULLION

Visible

MINIMUM SIZE

12"w x 12"h

UNDERSIZED

1/4" under ordered size unless specified Exact or Actual

SCREEN

3/4" x .051" flattened expanded aluminum bird screen in frame

FINISH

Mill

OPERATOR

Wing-nut adjustable

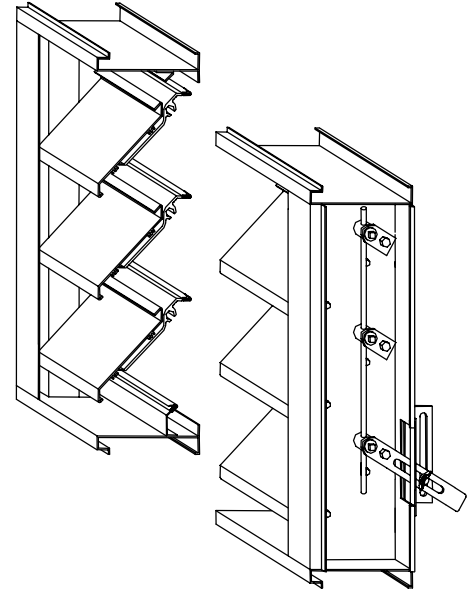

MULLION STYLE

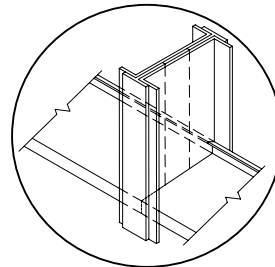

Visible

PERFORMANCE

Point of water penetration
886 fpm (270)

Free area
48 x 48 section
44%

OPTIONAL CONSTRUCTION

FRAME – Available in a heavier extrusion of .125"

BLADES - Available in a heavier extrusion of .125"

JAMB SEALS -Stainless steel jamb seals

SCREEN - Many styles available please consult screen listing

LINKAGE – Blade mounted

FINISH – Air-dry primer, polyurethane, epoxy, or enamel, baked epoxy or enamel, Kynar, or Powder coat.

OPERATOR – Manual, Electric or Pneumatic

SPECIAL PURPOSE CONSTRUCTION

Welded linkage

Security bars

Filter racks

Sleeved for ductwork connection

Jackshaft when required

TYPICAL SCREEN STYLES

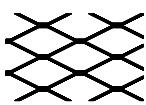

Expanded Aluminum Standard

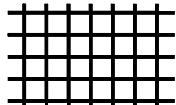

Wire Mesh

FRAME STYLES

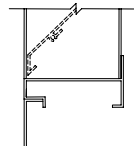

(1) - Flange 1-1/2"

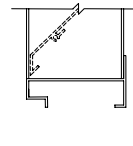

(3) - Box Standard

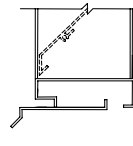

(8) - Box and Sill Extension

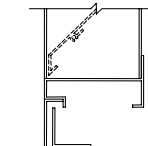

(9) - Flange w/ sub frame

DATE	ARCHITECT			CUSTOMER
PROJECT				
ITEM	QTY	W	H	DESCRIPTION

All tests performed at an independent laboratory and based on AMCA standard 511 – 91 for air performance and water penetration.

AIR PERFORMANCE

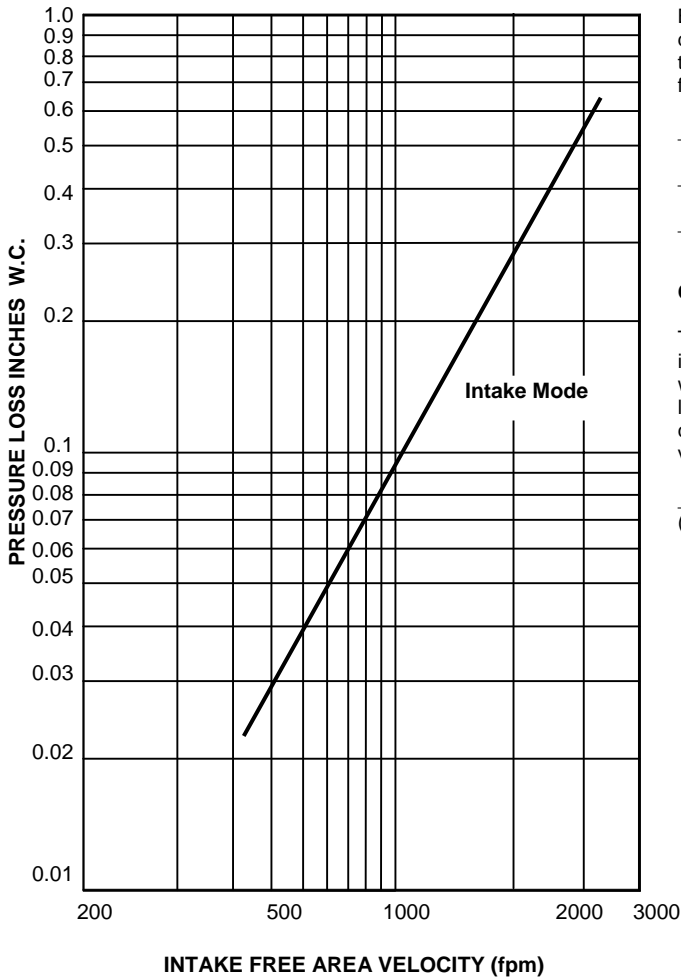

CALCULATING PRESSURE LOSS

Based upon a given flow rate (in CFM), the flowing pressure loss may be determined from the "air performance" graph, knowing the sq. ft. of free area of the louver. Alternately, the free area may be determined based upon a volumetric flow rate and a maximum pressure loss. Utilizing the "air performance" graph.

_____ in. W.C. Max. Pressure Loss Intake or Exhaust
 _____ FPM (Free Area Velocity From "Air Performance" Graph)
 _____ CFM / _____ FPM Free Area Velocity = _____ Sq. Ft. Free Area

CALCULATING MAXIMUM AIRFLOW BEFORE WATER PENETRATION

The "free area flow rate" at which water penetration commences (.01 oz. of water) is established at, 886 fpm for C-LEC-46, and will vary depending upon actual weather conditions. The "water penetration" graph illustrates the results of actual laboratory test on a 48" x 48" test sample subjected to hypothetical rainfall conditions. To determine the free area (in sq. ft.) based on upon a known volumetric flow rate in CFM;

_____ CFM / _____ FPM = _____ SQ. FT. FREE AREA
 (System Requirements)

Water Penetration Graph
 in oz. of water per sq. ft. of _____ .01 .02 .05 .1 .2 (H2O)
 free area over a 15 min. test period 886 938 1005 1056 1107 (fpm)

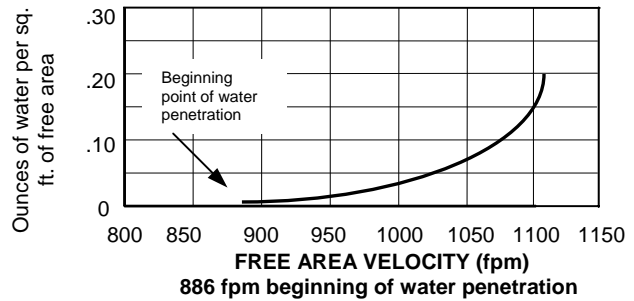

FREE AREA CALCULATIONS IN SQ. FT.

WIDTH

Inches	12	18	24	30	36	42	48	54	60
	(305)	(457)	(610)	(762)	(914)	(1067)	(1219)	(1372)	(1524)
12 (305)	.21 (.02)	0.35 (.03)	0.50 (.05)	0.64 (.06)	0.74 (.07)	0.94 (.09)	1.08 (.10)	1.23 (.11)	1.37 (.13)
18 (457)	.41 (.04)	0.69 (.06)	0.98 (.09)	1.27 (.12)	1.55 (.14)	1.84 (.17)	2.12 (.20)	2.41 (.22)	2.70 (.25)
24 (610)	.59 (.05)	1.01 (.09)	1.43 (.13)	1.85 (.17)	2.27 (.21)	2.69 (.25)	3.11 (.29)	3.53 (.33)	3.95 (.37)
30 (762)	.78 (.07)	1.33 (.12)	1.89 (.18)	2.44 (.23)	2.99 (.28)	3.54 (.33)	4.10 (.38)	4.65 (.43)	5.20 (.48)
36 (914)	.97 (.09)	1.66 (.15)	2.34 (.22)	3.03 (.28)	3.71 (.34)	4.40 (.41)	5.08 (.47)	5.77 (.54)	6.45 (.60)
42 (1067)	1.16 (.11)	1.98 (.18)	2.79 (.26)	3.61 (.34)	4.43 (.41)	5 (.49)	6.07 (.56)	6.88 (.64)	7.70 (.72)
48 (1219)	1.35 (.13)	.3 (.28)	3.25 (.30)	4.20 (.39)	5.15 (.48)	6.10 (.57)	7.05 (.65)	8.00 (.74)	8.95 (.83)
54 (1372)	1.53 (.14)	2.62 (.24)	3.70 (.34)	4.79 (.44)	5.87 (.55)	6.95 (.65)	8.04 (.75)	9.12 (.85)	10.20 (.95)
60 (1524)	1.75 (.16)	2.98 (.28)	4.21 (.39)	5.44 (.51)	6.67 (.62)	7.91 (.73)	9.14 (.85)	10.37 (.96)	11.60 (1.08)
66 (1676)	1.96 (.18)	3.34 (.31)	4.72 (.44)	6.10 (.57)	7.48 (.69)	8.86 (.82)	10.24 (.95)	11.62 (1.08)	13.00 (1.21)
72 (1829)	2.17 (.20)	3.69 (.34)	5.22 (.48)	6.75 (.63)	8.28 (.77)	9.81 (.91)	11.34 (1.05)	12.87 (1.20)	14.40 (1.34)
78 (1981)	2.38 (.22)	4.05 (.38)	5.73 (.53)	7.41 (.69)	9.09 (.84)	10.76 (1.00)	12.44 (1.16)	14.12 (1.31)	15.80 (1.47)
84 (2134)	2.59 (.24)	4.41 (.41)	6.24 (.58)	8.06 (.75)	9.89 (.92)	11.72 (1.09)	13.54 (1.26)	15.37 (1.43)	17.19 (1.60)
90 (2286)	2.80 (.26)	4.77 (.44)	6.75 (.63)	8.72 (.81)	10.69 (.99)	12.67 (1.18)	14.64 (1.36)	16.62 (1.54)	18.59 (1.73)
96 (2438)	3.01 (.28)	5.13 (.48)	7.25 (.67)	9.38 (.87)	11.50 (1.07)	13.62 (1.27)	15.74 (1.46)	17.87 (1.66)	19.99 (1.86)

HEIGHT