

Dynamic Integral Sleeve Curtain Fire Damper Model – D-150-12OV, 14OV, 16OV

Features – U.L. rated 1 ½ hour fire damper, for use in a 2 hour fire partition. • Meets NFPA 90A & UL 555 • Meets California State Fire Marshal Requirements.

STANDARD CONSTRUCTION

FRAME AND SLEEVE

- 150-12OV 12" x 20 gauge galvanized steel
- 150-14OV 14" x 20 gauge galvanized steel
- 150-16OV 16" x 20 gauge galvanized steel

BLADES

- 3 3/8" wide 22 gauge galvanized steel

MAXIMUM SINGLE OVAL SECTION

- 22"w x 20"h (Duct Size)

MINIMUM OVAL SIZE

- 4"w x 4"h

UNDERSIZED

- ¼" undersize unless specified otherwise

FUSIBLE LINK

- 165° standard (others available)

SPRINGS

- Stainless steel – 301 Negator type

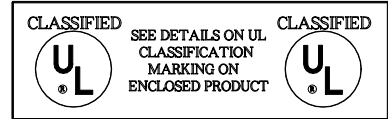

OPTIONAL CONSTRUCTION

WELDED CONSTRUCTION

"D" STYLE – Low Pressure applications

RETAINING ANGLES – Shipped loose

SECURITY BARS – Mounted in sleeve

FUSIBLE LINK – Electrically triggered link (ETL)

Damper is a rollformed 20 ga. steel frame and sleeve combination

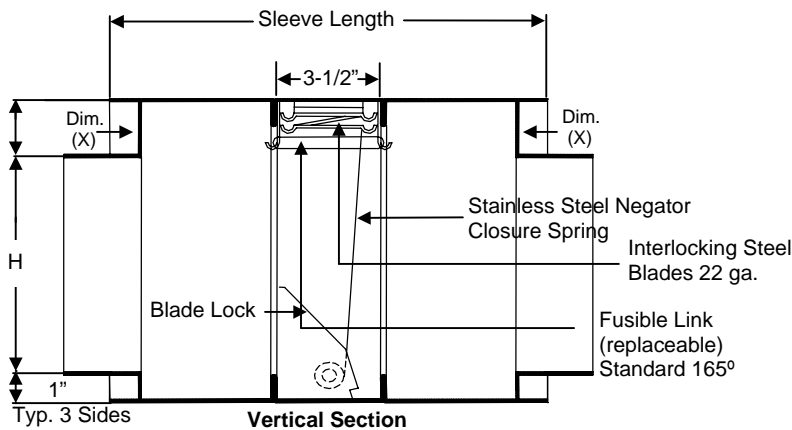
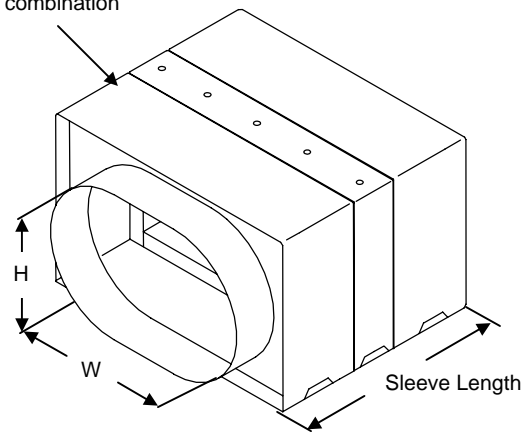

Duct Height	Dim. (X)
4" thru 15"	2"
16" thru 24"	3"

DATE	ARCHITECT			ENGINEER
PROJECT				
ITEM	QTY	W	H	DESCRIPTION



DEPENDABLE PRODUCTS SINCE 1955

SAFE-AIR OF ILLINOIS, INC.

Engineering and General Offices
1855 South 54th Avenue, Cicero, Illinois 60804
Phone 708-652-9100 FAX 708-652-9158