

## Dynamic Integral Sleeve Curtain Fire Damper - MODEL D-300-12A,14A, 16A

**Features** – U. L. Rated for 3-hour fire damper, for use in a 4-hour fire partition. • Meets NFPA 90A & UL555 Meets California State Fire Marshal Requirements.

### STANDARD CONSTRUCTION

#### FRAME AND SLEEVE

- 300-12A 12" x 20 gauge galvanized steel
- 300-14A 14" x 20 gauge galvanized steel
- 300-16A 16" x 20 gauge galvanized steel

#### BLADES

- 3-3/8" wide 22 gauge galvanized steel

#### UNDERSIZED

- 1/4" undersize unless specified otherwise

#### FUSIBLE LINK

- 165°F standard (others available)

#### SPRINGS

- Stainless steel – 301 Negator type

#### MAXIMUM SINGLE SECTION

- Vertical: 24" w x 24" h

#### MINIMUM SIZE

- Vertical: 4" w x 4" h

#### MAXIMUM STATIC PRESSURE

- 4" WG @ 2000 FPM

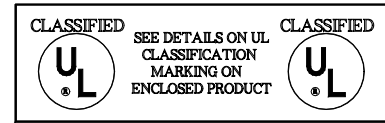

Damper is a roll formed 20 ga. steel frame and sleeve combination

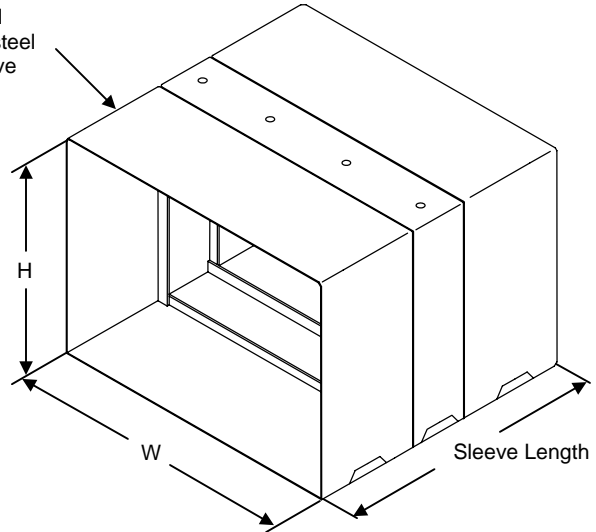

### OPTIONAL CONSTRUCTION

**RETAINING ANGLES** – Shipped Loose

**SECURITY BARS** – Mounted in sleeve

**FUSIBLE LINK** – Electronically triggered link (ETL)

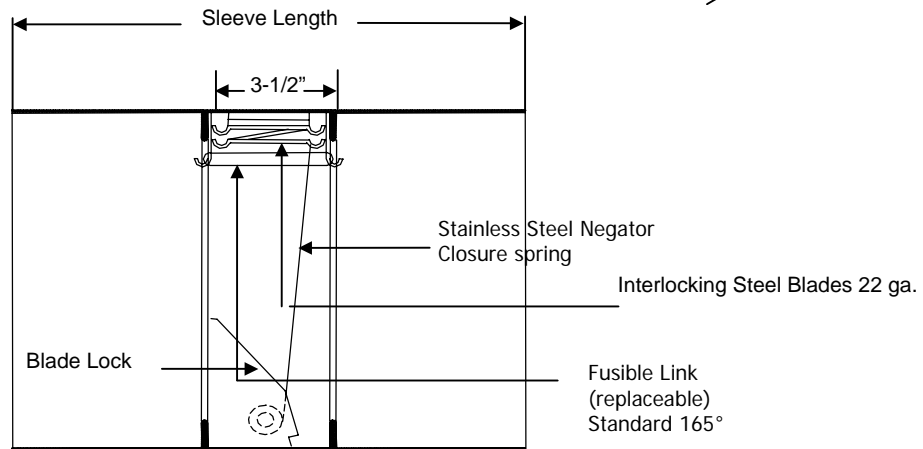

Vertical Section

(Not available in horizontal)

DATE	ARCHITECT			CUSTOMER
PROJECT				
ITEM	QTY	W	H	DESCRIPTION



DEPENDABLE PRODUCTS SINCE 1955

**SAFE-AIR/DOWCO**

*Engineering and General Offices*

1855 South 54<sup>th</sup> Avenue, Cicero, Illinois 60804

Phone 708-652-9100 FAX 708-652-9158