

Dynamic Integral Sleeve Curtain Fire Damper - MODEL D-300-12B,14B, 16B

Features – U. L. Rated for 3-hour fire damper, for use in a 4-hour fire partition. • Meets NFPA 90A & UL555 Meets California State Fire Marshal Requirements.

STANDARD CONSTRUCTION

FRAME AND SLEEVE

- 300-12B 12" x 20 gauge galvanized steel
- 300-14B 14" x 20 gauge galvanized steel
- 300-16B 16" x 20 gauge galvanized steel

BLADES

3-3/8" wide 22 gauge galvanized steel

MAXIMUM SINGLE SECTION

Vertical: 24" w x 21" h (duct size)

MINIMUM SIZE

Vertical: 4" w x 4" h

UNDERSIZED

1/4" undersize unless specified otherwise

FUSIBLE LINK

165° standard (others available)

SPRINGS

Stainless steel – 301 Negator type

MAXIMUM STATIC PRESSURE

4" WG @ 2000 FPM

OPTIONAL CONSTRUCTION

RETAINING ANGLES – Shipped Loose

SECURITY BARS – Mounted in sleeve

FUSIBLE LINK – Electronically triggered link (ETL)



03225-0751-001

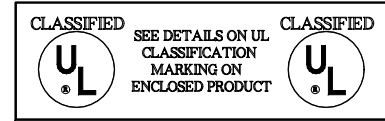

Damper is a roll formed 20 ga. steel frame and sleeve combination

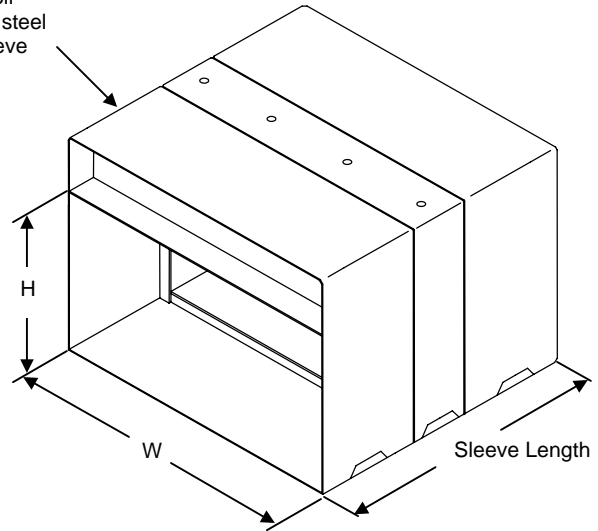

| Duct Height | Dim. (X) |
|--------------|----------|
| 4" thru 15" | 2" |
| 16" thru 21" | 3" |

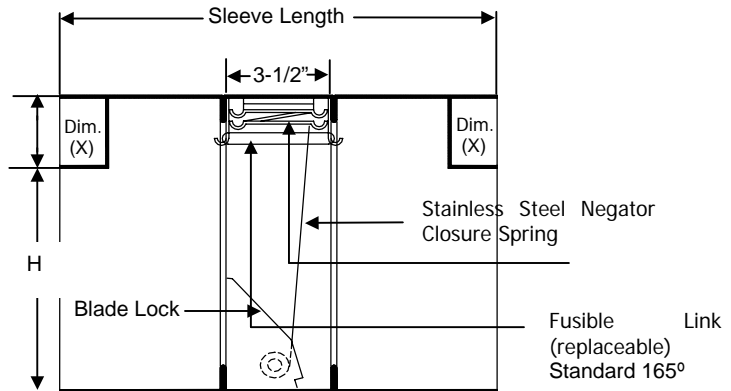

Vertical Section

(Not available in horizontal)

| | | | | | |
|---------|-----|-----------|---|-------------|--|
| DATE | | ARCHITECT | | CUSTOMER | |
| PROJECT | | | | | |
| ITEM | QTY | W | H | DESCRIPTION | |
| | | | | | |
| | | | | | |
| | | | | | |
| | | | | | |
| | | | | | |