

Dynamic Curtain Fire Damper - MODEL D-300-12RC, 14RC, 16RC

Features – U. L. Rated for 3-hour fire damper, for use in a 4-hour fire partition. • Meets NFPA 90A & UL555 Meets California State Fire Marshal Requirements.

STANDARD CONSTRUCTION

FRAME AND SLEEVE

- 300-12RC 12" x 20 gauge galvanized steel
- 300-14RC 14" x 20 gauge galvanized steel
- 300-16RC 16" x 20 gauge galvanized steel

BLADES

- 3-3/8" wide 22 gauge galvanized steel

UNDERSIZED

- 1/4" undersize unless specified otherwise

FUSIBLE LINK

- 165° standard (others available)

SPRINGS

- Stainless steel – 301 Negator type

MAXIMUM SINGLE SECTION

- 22" w x 21" h (Duct Size)

MINIMUM SIZE

- 4" w x 4" h

MAXIMUM STATIC PRESSURE

- 4" WG @ 2000 FPM



03225-0751-001

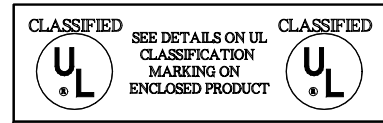

Damper is a roll formed 20 ga. steel frame and sleeve combination

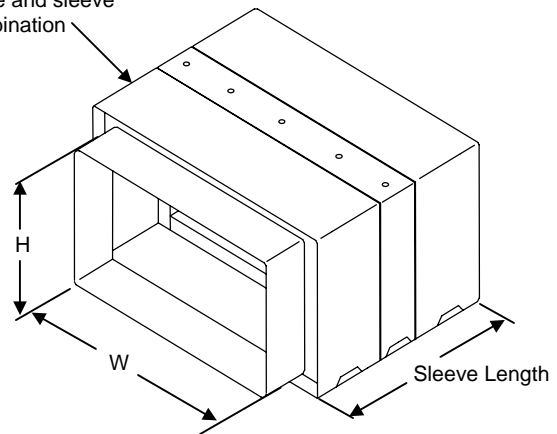

OPTIONAL CONSTRUCTION

WELDED CONSTRUCTION

“D” STYLE – Low Pressure applications

RETAINING ANGLES – Shipped loose

SECURITY BARS – Mounted in sleeve

FUSIBLE LINK – Electrically triggered link (ETL)

Duct Height	Dim. (X)
4" thru 15"	2"
16" thru 21"	3"

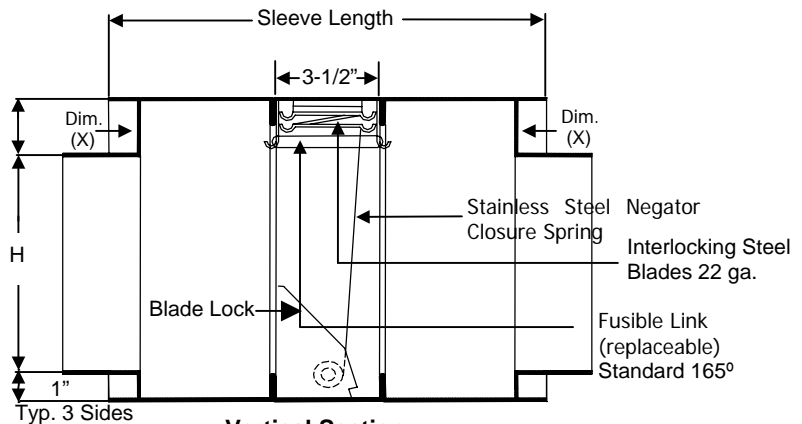

Vertical Section

(Not available in horizontal)

DATE		ARCHITECT		CUSTOMER	
PROJECT					
ITEM	QTY	W	H	DESCRIPTION	



DEPENDABLE PRODUCTS SINCE 1955

SAFE-AIR/DOWCO

Engineering and General Offices

1855 South 54th Avenue, Cicero, Illinois 60804

Phone 708-652-9100 FAX 708-652-9158