

Dryer Vent Damper Model DVD-R

Features – Economical Medium Duty Backdraft Damper

Please Specify Horizontal or Vertical Airflow

STANDARD CONSTRUCTION

FRAME

4" deep, 20 gauge galvanized steel

BLADES

20 gauge galvanized steel

BLADE AXLES & BEARINGS

AXLES - 3/16" steel screw

BEARINGS - Brass sleeve

MAXIMUM VELOCITY & STATIC PRESSURE

2000 FPM @ 2" w.g.

MAXIMUM SIZE

24" Diameter

MINIMUM SIZE

4" Diameter

UNDERSIZED

1/8" under ordered size unless specified Exact or Actual

FINISH

Mill

OPERATOR

None

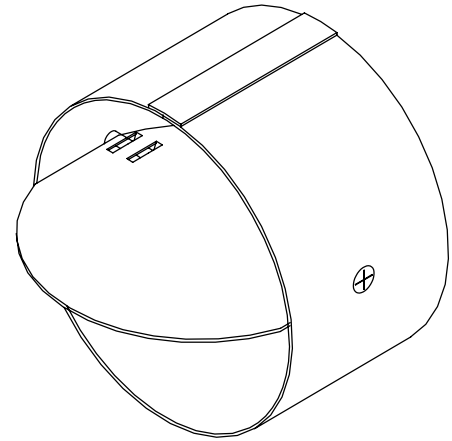

ISOMETRIC VIEW

OPTIONAL CONSTRUCTION

FRAME – Available in galvanized steel construction up to 10 gauge

BLADES – Available in galvanized steel construction up to 14 gauge

SPECIFIED MATERIAL – Available in Stainless, Aluminum or as requested

SLEEVE AND DUCTWORK CONNECTION – 10 ga. to 20 ga. galvanized steel to 30" in length.

FINISH – Paint is available

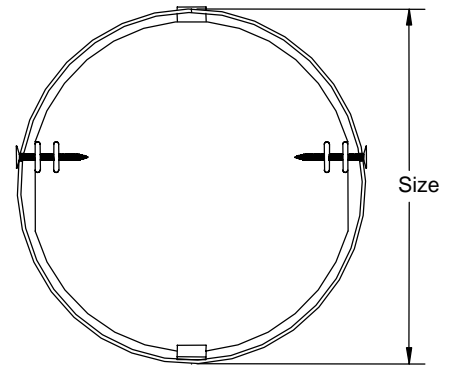

ELEVATION

DATE	ARCHITECT/ENGINEER			CUSTOMER
PROJECT				
ITEM	QTY	W	H	DESCRIPTION



DEPENDABLE PRODUCTS SINCE 1955

SAFE-AIR / DOWCO

Engineering and General Offices

1855 South 54th Avenue / Cicero, Illinois 60804

Phone: 708-652-9100 FAX: 708-652-9158