

These are the instructions on how to properly assemble your penthouse. The steps listed below must be followed in an orderly manner. However, depending on actual field condition and manpower, the following are just minimum suggested steps only. The installer shall be responsible for adding additional structural supports if necessary, caulking and to fully comply in accordance with the approved shop drawing and specifications.

### RECEIVING/INSPECTION

Upon delivery, inspect shipping containers and contents closely. If shipping containers are damaged, contents could be also be damaged. Note any damage on truckers' receipt. Contact the freight company within 24 hours for inspection.

### STORAGE

Store in an orderly manner at a safe location away from construction, traffic, material, etc. to prevent damage. Cover with plastic sheeting to protect from excessive moisture, dirt, and debris.

### PRE-ASSEMBLY

1. Remove the louvers, roofs, and insulation (if any) from the shipping container and inspect for damage. Care must be taken when handling. **Lift by the frame and supports – NOT BY THE BLADE.** Do not drop, drag, step on, or apply excessive force on louvers and roofs.
2. Inspect and locate roof curb openings where penthouses are to be installed by their markings or labels on louver frame or underside of the roof.

### TOOLS NEEDED

- 1 Ratchets wrench with a socket
- 2 Electric drill
- 3 Vise grip "C" style clamps
- 4 Tape measure
- 5 Drill bits – 3/16"
- 6 #10 x 1-1/2" self-tapping screws, 1/4" x 1-1/2" masonry tapcon screws

### LOUVER WALL ASSEMBLY

1. Position louver end sections together. Align and match frame markings on (4) corners. **See Figure (A)** Fasten 2" x 2" vertical angle supports from the interior side to opposite louver section using #10-16 x 1-1/2" screws spaced @ 12" o.c. Fasten post corner from the exterior side to adjacent louver section using the same fasteners and spacing.
2. For penthouse with mitered corners, position (4) louver end sections together and secure temporarily, align blades from the exterior side and match frame markings on adjacent sections, fasten the two angles together. **See Figure (B)**
3. On multiple section assemblies with visible mullions, install the louver section. Within the T-mullion, align and match frame markings or labels on adjacent sections. Normally T-mullions are factory mounted. Fasten the two angles together leaving 1/8" or more for expansion joint. **See Figure (C)**
4. Align T-mullions on adjacent frames. Fasten together with self-tapping screws spaced approximately @ 18" o.c.
5. On multiple section assemblies with invisible mullions, align blade from the exterior side and match frame markings or labels on adjacent sections, fasten the two angles together leaving 1/8" or more expansion joint. **See Figure (D)**
6. Fasten sill cap @ 12" o.c. from the exterior side to the roof curbs. **See Figure (E)**. If with concrete curb secure penthouse with tapcon masonry screws 1/4" dia. x 1-1/2" long minimum of (2) per vertical support. **See Figure (H)**

### ROOF ASSEMBLY

1. Position roof sections together and locate center and end sections. Center sections should be open on each end and end sections should have a panel on one side. Markings should be located on the underside of pre-assembled roof.
2. Align sections together and fasten with roof strip overlapping about 1" then caulk thoroughly. **See Figure (F)**
3. Fasten roof assembly to head louver frame from the exterior side. Make sure roof rafter is directly resting on vertical support. **See Figure (G)**
4. Fasten diagonal bracing (if required) to interior vertical supports and roof rafter. **See Figure (G)**

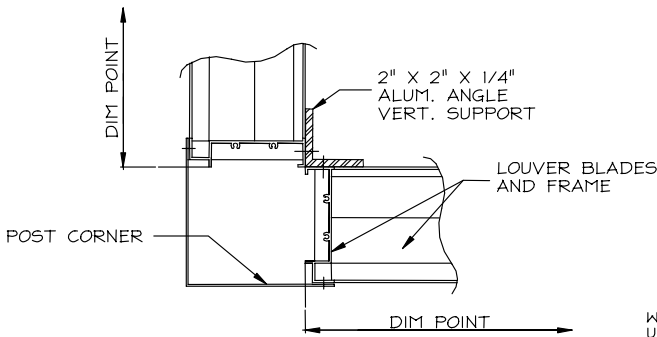

(A)

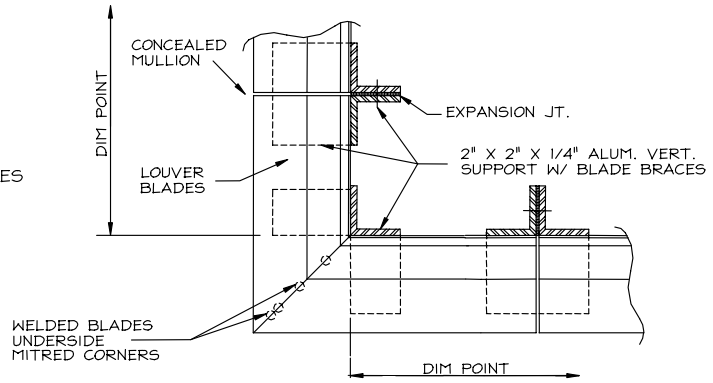

(B)

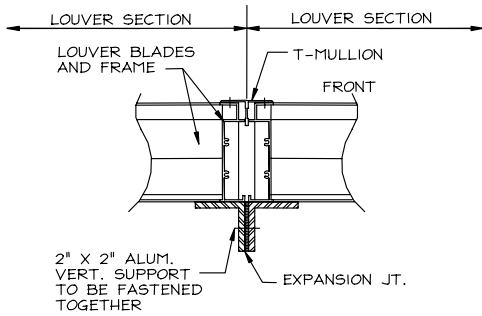

(C)

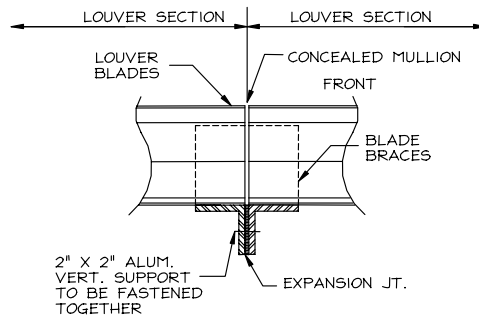

(D)

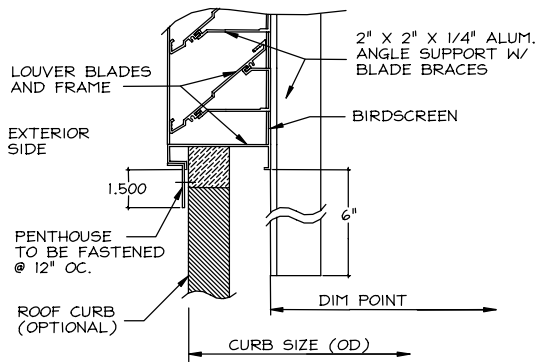

(E)

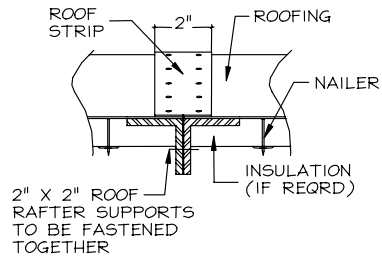

(F)

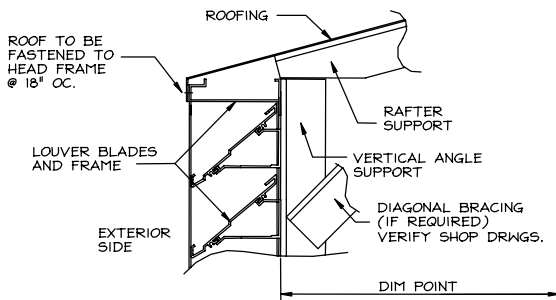

(G)

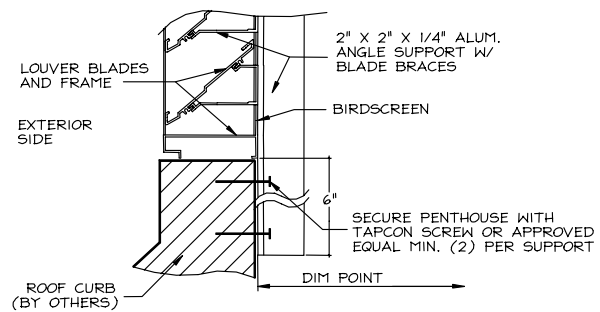

(H)