

VANE INLET DAMPER Model - VID

Primary Function – Designed for flow and modulation of CLASS I and CLASS II fans in clean or moderately dirty flow streams.

STANDARD CONSTRUCTION

FRAME

12 Ga. Galvanized Steel (see table below)

BLADES

16 Ga. Galvanized Steel

BLADE AXLES & BEARINGS

AXLE – 1/2" diameter plated steel

BEARING – stainless steel with trust washers

HUB

Open – 12 Ga. Galvanized Steel

LINKAGE

Plated Steel

MIN. & MAX. TEMPERATURE

-40° F to 250° F

MAXIMUM SIZE

72" Diameter

MINIMUM SIZE

12" Diameter

FINISH

Shop Primer

ACTUATOR

None

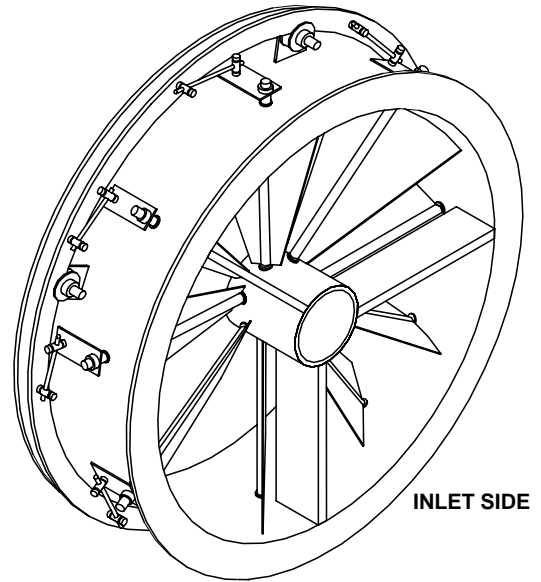

INLET SIDE

Specify Rotation of Inlet Air as Viewed From Inlet Side

OPTIONAL CONSTRUCTION

SPECIFIED MATERIAL – Available in stainless steel

BLADE AXLES & BEARINGS – 3/4" to 2" dia

FINISH – Air-dry primer, polyurethane, epoxy, or enamel.
Baked epoxy or enamel. For industrial special purpose coating, please consult Dowco.

BOLT HOLES – Based on standard bolt circles available

ACTUATORS – Manual, Electric, or Pneumatic.

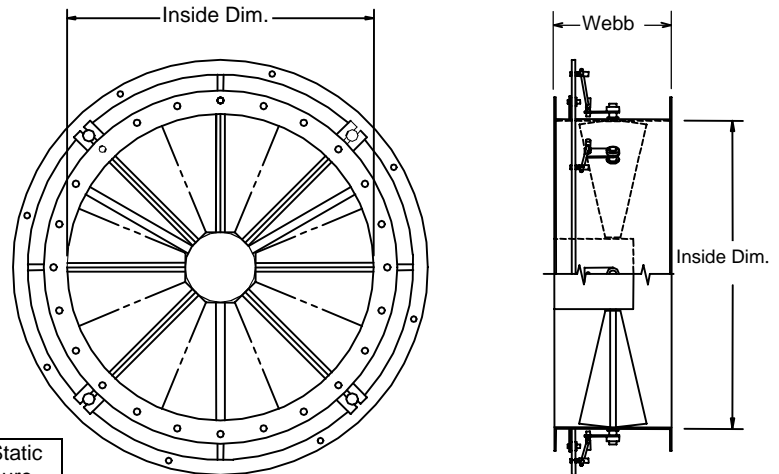

Bolt holes are optional

SPECIAL PURPOSE CONSTRUCTION

For higher temperatures and velocities, please consult Dowco.

FRAME DIMENSIONS				
Inside Dim. (dia.) from to		Flange	Webb	Max. Static Pressure
12"	25"	1-1/2 x 12 ga.	9" x 10 ga.	8" wg.
26"	42"	2 x 3/16 thk.	9" x 3/16"	8" wg.
43"	60"	2 x 3/16 thk	10" x 3/16"	6" wg.
61"	72"	2-1/2 x 3/16 thk	12" x 1/4"	4" wg.

DATE		ARCHITECT / ENGINEER			CUSTOMER	
PROJECT						
ITEM	QTY	W	H	DESCRIPTION		

All tests performed at an independent laboratory and based on AMCA standards for air performance.

AIR PERFORMANCE

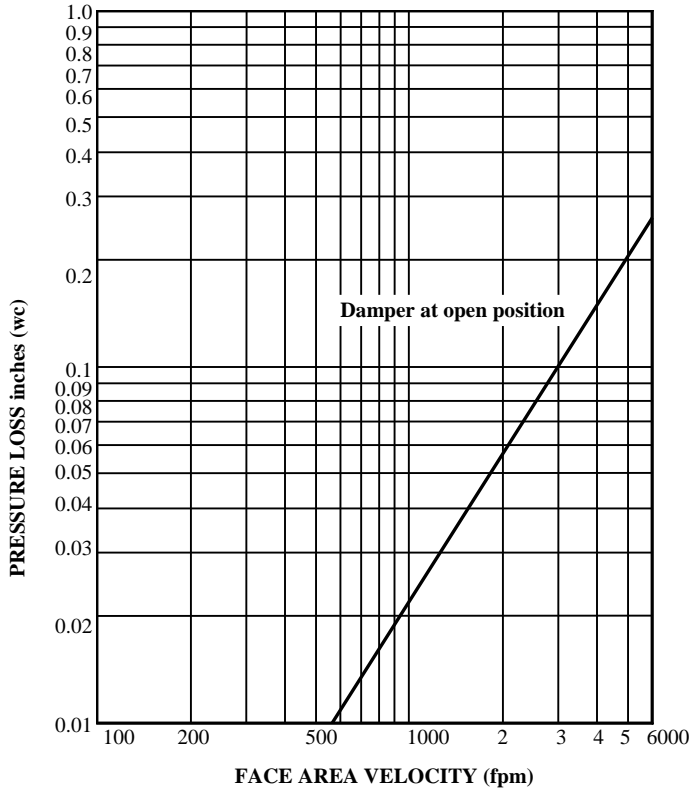

24" diameter sample tested per AMCA Std. 500, Figure 5.3

AIR LEAKAGE

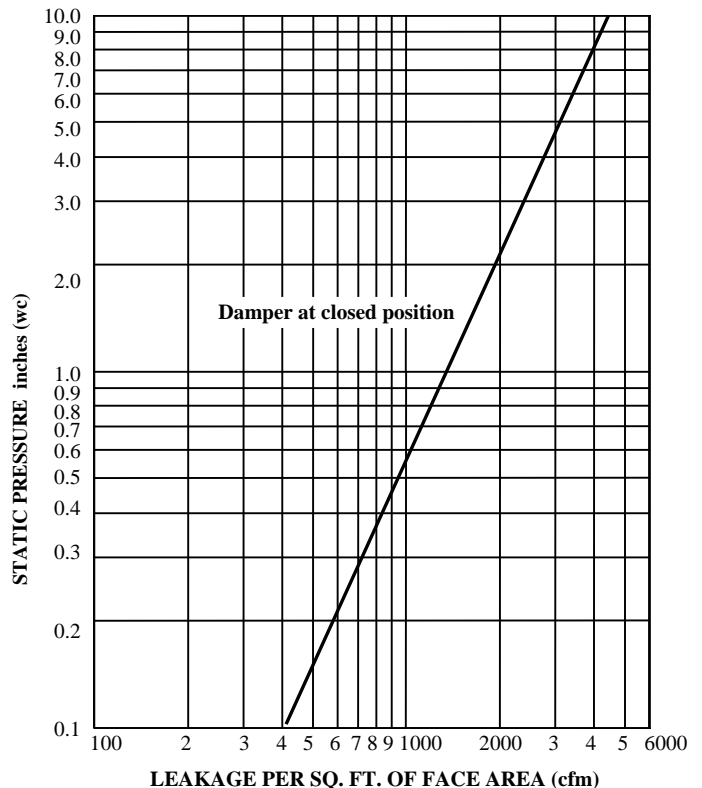

48" diameter sample tested per AMCA Std. 500, Figure 5.5

CALCULATING PRESSURE LOSS

Based upon a given flow rate (in CFM), the flowing pressure loss may be determined from the "air performance graph", knowing the sq. ft. of face area of the damper. Alternately, the face area may be determined based upon a volumetric flow rate and a maximum pressure loss. Utilizing the "air performance" graph.

_____ in. W.C. Max. Pressure Loss Intake or Exhaust
 _____ FPM (Face Area Velocity From "Air Performance" Graph)
 _____ CFM / _____ FPM Free Area Velocity = _____ Sq. Ft. Face Area

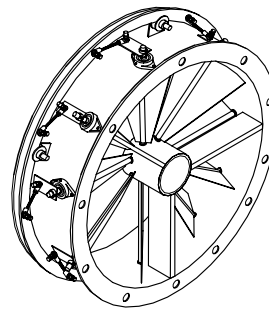

With 2-bolt flange bearing

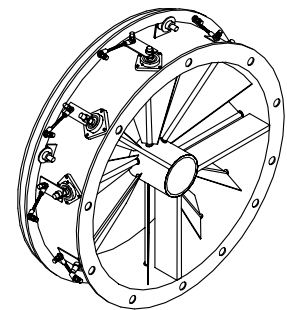

With 4-bolt flange bearing

STANDARD BOLT HOLE PATTERN FOR VANE INLET DAMPERS				
Order Size (Inches)	Flange (F)	Holes Size (Diameter)	Number of Holes	Bolt Circle Factor
12 to 18	1-1/2"	7/16"	8	2"
19 to 22	1-1/2"	7/16"	12	1-3/4"
23 to 24	1-1/2"	7/16"	12	1-7/8"
25	1-1/2"	7/16"	16	1-7/8"
26 to 36	2"	7/16"	16	2-3/8"
37 to 50	2"	7/16"	24	2-3/8"

- Actual I. D. Size = Order Size + 1/8"
 - Actual O. D. Size = Actual I. D. Size + (F x 2)
 - Bolt Circles = Order Size + Bolt Circle Factor
- Bolt holes start perpendicular to blade axles (12 o'clock)

