

FIRE DAMPER
MASONRY / CONCRETE OR METAL STUD WALL INSTALLATION INSTRUCTIONS
UL FILE # R 7861 IN ACCORDANCE WITH UL 555

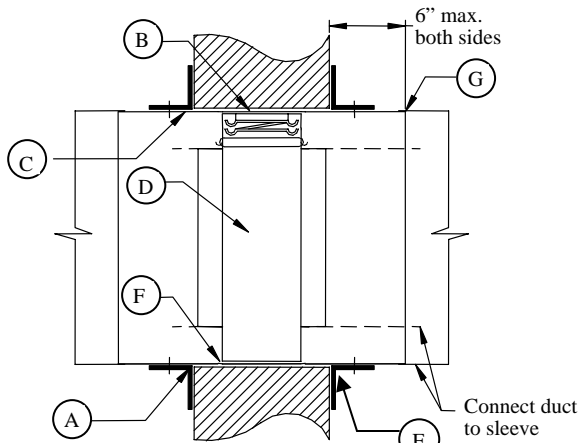

Vertical/Horizontal Mount
2-sided mounting angles

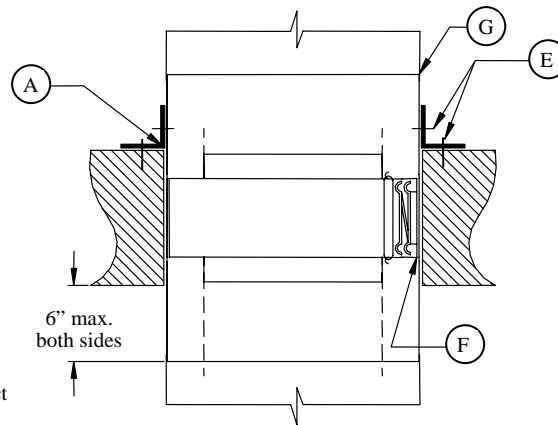

Vertical/Horizontal Mount
1-sided mounting angle

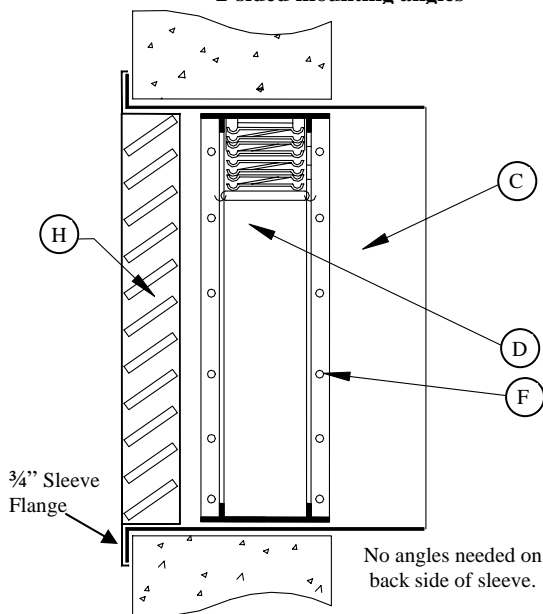

Grille/Louver or shaft mount

Typical installation details

- (A) Retaining Angles: Minimum 1 1/2" x 1 1/2" x 0.054 (18ga)
Retaining angles must lap structural opening 1" minimum and cover corners of openings.
- (B) Clearance: 1/8" inch per linear foot both dimensions (see Note 1 below)
- (C) Steel sleeve: See sleeve schedule
- (D) Approved Fire Damper (curtain or blade type)
Damper must be in the wall.
- (E) Secure retaining angles 8" on centers with:
 - ◆ 1/2" long welds or
 - ◆ 1/4" Bolts and nuts, or
 - ◆ No. 10 steel screws, or
 - ◆ Minimum 1/16" steel rivets
 - ◆ For 1-sided only secure angle to wall/floor & sleeve
 - ◆ For 2-sided only secure angle to sleeve only
 - ◆ For concrete, use anchors and # 10 self-tapping screws

- (F) Secure damper to sleeve 8" on centers with:
 - ◆ 1/2" long Welds, or
 - ◆ 1/4" bolts and nuts in holes provided, or
 - ◆ No. 10 steel screws, or
 - ◆ Minimum 3/16" steel rivets
- (G) Connect ducts to sleeve with approved or equal duct collar connections/ break-away connections.
- (H) Grille to be supplied by others.

Notes:

Fire damper sleeve clearance within wall opening.

1. Clearance requirements between sleeve and wall or floor shall be minimum of 1/8 per foot of width and height of sleeve. The maximum size of opening shall be 2" larger in width or height than the allowed minimum size. The sleeve may rest on the bottom of the opening, and need to be centered. (Fractional dimensions shall be taken as the next largest whole foot.)

Example: A 30-inch x 24-inch fire damper sleeve is installed in a wall opening. The opening shall be 30-3/8 inches wide (1/8 inch x 3 feet) by 24-1/4 inches high (1/8 inch x 2 feet).

Minimum of 1/4" gap on width and height.

2. The sleeve is retained in the wall opening by the use of steel retaining angles (A). These must over-lap the edge of the framing by a minimum of one (1) inch over and beyond all the retaining angle would be 1-3/8 inches (good practice calls for an additional safety factor by making the angle in this case 1-1/2 inches wide).
3. The dimensions required for the opening shall be those remaining after the opening has been framed and fire resistive materials provided were required. The fire resistive materials shall be equal to the requirements for fire resistive materials used in the constructed wall so that a continuous rating exists at the wall penetration. The contractor erecting the wall is responsible for providing the fire resistive material and correct size openings to achieve the required clearance.
4. Dampers must be installed in accordance with these instructions to meet the requirements of UL 555. The installation of the damper and all duct connections to the damper sleeve shall conform to the latest editions of NFPA 90A, Standard for the installation of Air Conditioning and Ventilating Systems, and the SMACNA Fire, Smoke and Radiation damper installation guide, and U.L. Classifications R7861.