

**INSTALLATION INSTRUCTIONS - SMOKE DAMPER  
MODELS 621, 622, 622M, 661, 681, AND 682**

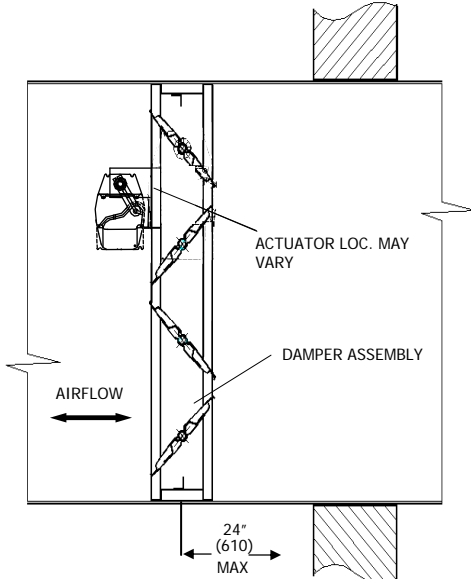

**Damper Installed at Smoke Partition  
Vertical or Horizontal Mount Shown**

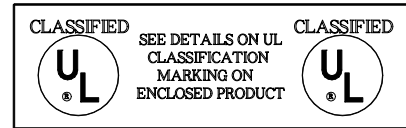

**Typical Installation Instructions**

1. Leakage rated dampers can be installed in accordance with NFPA 90A and 92A.
2. Damper shall not be forced into the wall opening; this will cause the damper to get out of square and will not work properly. Sleeve shall not exceed more than 24" (610) beyond the face of the wall on both sides.
3. Damper shall be attached to duct / sleeve using 1/2" (13) long welds or # 10 (M5) sheet metal screws 3/4" (19) long spaced @ 6" (152) maximum on center and 2" (51) maximum from corners.
4. Smoke Dampers must be placed in the ductwork so the closed blades are within 24" (610) of the smoke barrier and before any duct inlets or outlets (access doors not included)..
5. Make sure that damper unit remains squared in its enclosure and that the blades are not obstructed and the actuator and connection linkage are free from debris.
6. The following duct-unit connections may be used: (caulked connection as needed)
  - Inside slip
  - Plain "S" slip
  - Hemmed "S" slip
  - Bar slip
  - Alternate slip (standing slip)
  - Reinforced bar slip (cleat)
7. Caulk joints between sleeve and frame with the following approved sealant.
  - Dow Corning RTV #732
  - GE RTV #108

**Electric Damper Actuator Connection**

1. Before any connections are made, check the damper to be sure no physical damage has occurred during mechanical installation.
2. Bring the building electrical control wiring to the junction box (supplied by others) and connect. (Use method described in local code requirements).
3. Refer to manufacturers technical specification for electric actuators.

**Pneumatic Damper Actuator Connection**

1. Before any connections are made, check the damper to be sure no physical damage has occurred during the mechanical installation.
2. Install air supply to the actuator using 1/4" (6) dia. copper tubing or as required by local codes.
3. Refer to manufacturers technical specification for pneumatic actuators.

**APPROVED ACTUATORS**

	Honeywell	Siemens	Belimo
230 Vac -	ML 4115	GGD321.1U	FSNF120 US
120 Vac -	MS 4209	GGD221.1U	
	MS 4120		
24 Vac -	ML 8115	GGD121.1U	FSNF 24 US
	MS 4309		
Pneumatic -		331-2961	
		331-3060	

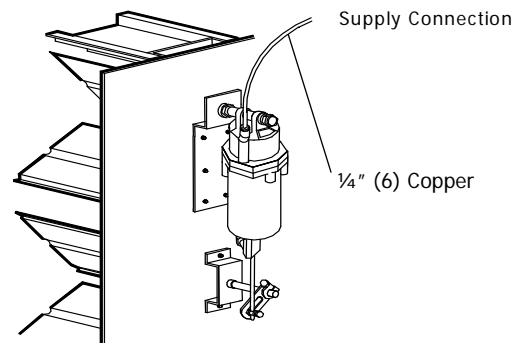

**Pneumatic Actuator**

**Trouble Shooting**

Each smoke damper is fully tested in our factory before shipment and although designed for rugged, long-life service mishandling in transit may cause minor field problems.

Most problems that occur are attributable to the following:

1. The damper frame is out of square that causes binding of the blades and prevents proper opening and cycling.
2. Foreign material between blades interfaces and prevents complete cycling.
3. Mis-positioned or unsecured actuator module prevents damper operation.

The above are overcome by carefully re-squaring the damper, inspecting and cleaning the blades interfaces, or correcting the actuator mounting position.