

ELEVATION @ INTERIOR SIDE

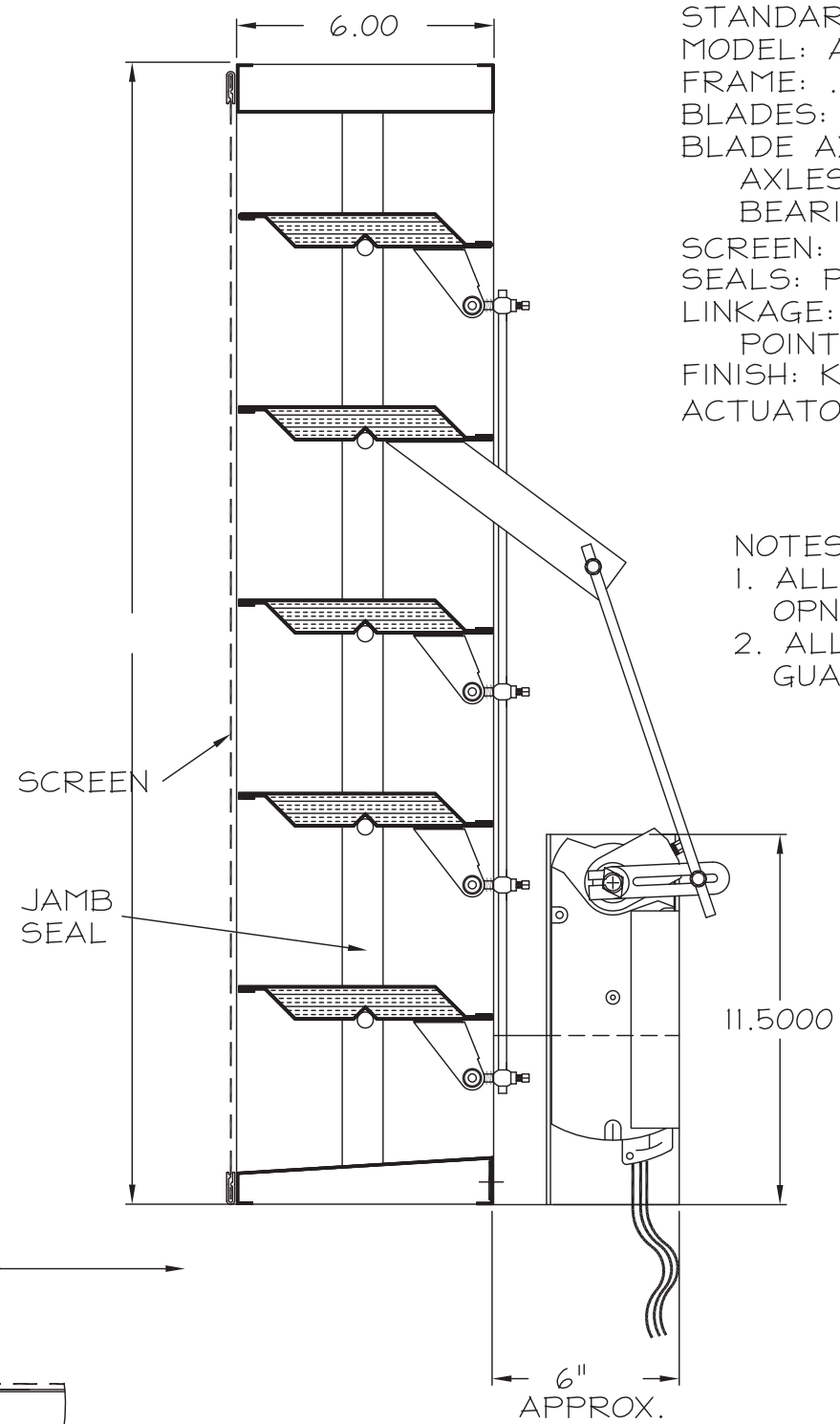

SECTION - "B"

STANDARD CONSTRUCTION  
 MODEL: AFI-06/SERIES  
 FRAME: .081" FORMED ALUM. 5005-H34  
 BLADES: .125" THK. FORMED ALUM. 5005-H34  
 BLADE AXLES AND BEARINGS:  
   AXLES - 1/2" DIA. PLATED STUB-SHAFT  
   BEARINGS - 1/2" BRONZE OILITE  
 SCREEN: 1/2" MESH X .063" ALUM. WIRE SCREEN IN FRAME  
 SEALS: POLYURETHANE FOAM BLADE & ALUM. JAMB SEALS  
 LINKAGE: PLATED STEEL, MOUNTED AT THE CENTER POINT OF BLADE  
 FINISH: KYNAR 500 3-STEP COLOR AS SELECTED  
 ACTUATOR: SIEMENS GGD221.IU 120 Vac 2-POSITON W/ SPRING RETURN

- NOTES:  
 1. ALL DAMPERS TO BE FABRICATED 1/4" UNDER LISTED OPNG SIZES UNLESS OTHERWISE SPECIFIED "ACTUAL".  
 2. ALL OPNG SIZES TO BE FIELD VERIFIED AND GUARANTEED BY OTHERS PRIOR TO FABRICATION.

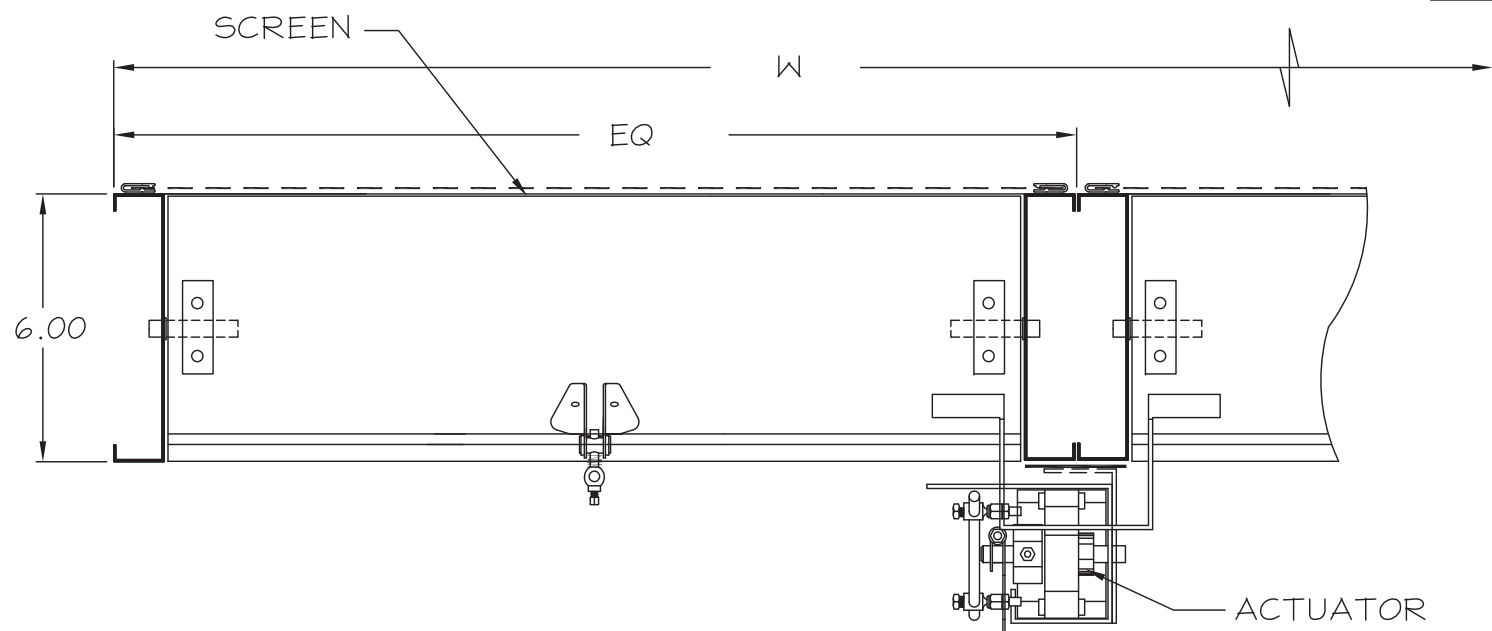

SECTION - "A"

**SAFE-AIR**  
**DOWCO**  
 1855 SOUTH 54TH AVENUE, CICERO, IL. 60650  
 DEPENDABLE PRODUCTS SINCE 1955

ARCH/ENGR: \_\_\_\_\_ CUSTOMER: \_\_\_\_\_

REV.	DESCRIPTION	DATE	BY	PROJECT:	TITLE:
					AFI-06/SERIES
				DATE:	DRAWN:
					CHKD:
					DRWG #: