

Range Hood Curtain Fire Damper - MODEL 155A

Features – U. L. Rated for 1-1/2 hour fire damper, for use in a 2-hour fire partition. • Meets NFPA 90A & UL555
Meets California State fire Marshal Requirements

STANDARD CONSTRUCTION

FRAME

4-7/8" deep, 22 gauge galvanized steel

BLADES

3-3/8" wide, 22 gauge galvanized steel

UNDERSIZED

1/4" under ordered size unless specified otherwise

FUSIBLE LINK

165° Standard (others available)

SPRING

Stainless Steel – 301 Negator type

Vertical – Optional

Horizontal – Standard

MINIMUM SIZE

4" w x 4" h (Vertical & Horizontal)

MAXIMUM SINGLE SECTION SIZE

Vertical – 24" w x 24" h

Horizontal – 24" w x 24" h

MAXIMUM MULTIPLE SECTION SIZE

Vertical – 48" w x 24" h

Horizontal – 48" w x 24" h

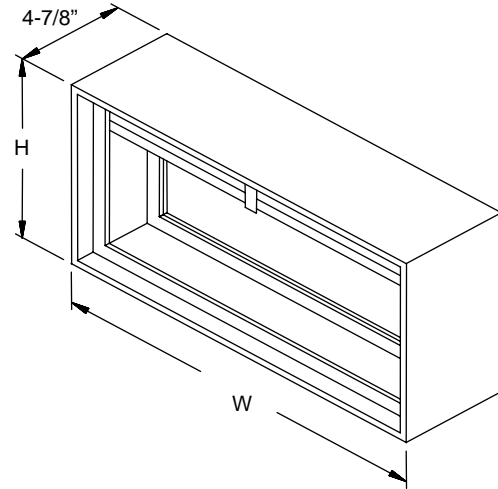
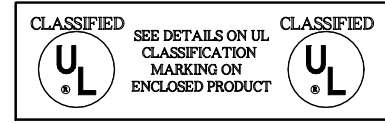

OPTIONAL CONSTRUCTION

SPRING - Available in vertical mount

FRAME – Available in Stainless Steel

BLADE – Available in Stainless Steel

FUSIBLE LINK – Electrically triggered link (ETL)

SLEEVE & DUCT CONNECTION – 10 ga. to 20 ga. galvanized steel to 30" in length. Transitions available in; round, oval, rectangular, or custom. Factory can install access door, retaining angles, flange connections or security bars.

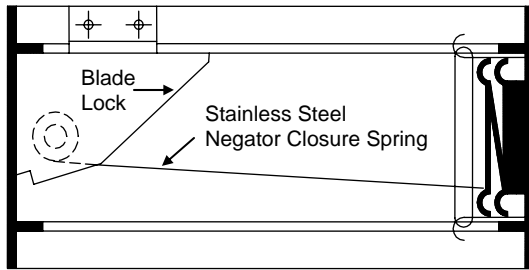

Horizontal Section

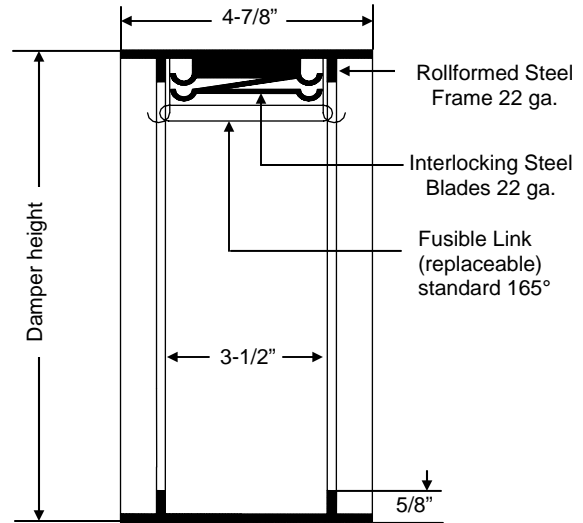

Vertical Section

DATE		ARCHITECT		CUSTOMER	
PROJECT					
ITEM	QTY	W	H	DESCRIPTION	



DEPENDABLE PRODUCTS SINCE 1955

SAFE-AIR/DOWCO

Engineering and General Offices

1855 South 54th Avenue, Cicero, Illinois 60804

Phone 708-652-9100 FAX 708-652-9158