

The Safe-Air Model 610R is a manual balancing, butterfly damper which has been designed for all types of round ductwork applications and is suitable for use in the majority of low pressure and velocity commercial HVAC systems. The 610R installs easily in round spiral ductwork.

The 610R is supplied as standard with a hand locking quadrant. They are not intended to be used in applications as a positive shut-off or automatic control damper.

STANDARD CONSTRUCTION:

FRAME: 22 ga. (0.86) corrosion-resistant steel with stiffening beads up to 12" (305) dia. 20 ga. (0.91) over 12" (305) dia.

BLADE: 22 ga. (0.86) corrosion-resistant steel up to 12" (305) dia., 20 ga. (1.0) over 12" (305) dia.

DRIVE SHAFT/

AXLE: 1/4" (6) square plated steel.

AVAILABLE SIZES: 4" (102) through 20" (508) diameter in nominal 1" (25) increments.

TEMPERATURE RANGE: -50°F to 250°F (-45°C to +121°C)

OPTIONS:

- SB** 2" (51) stand-off bracket for hand locking quadrant.
- BO** Oilite bearings.
- A38** 3/8" (9.5) square axle. No hand locking quadrant (control supplied by others).
- A38Q** 3/8" (9.5) square axle with matching hand locking quadrant.
- Special features _____ .

PERFORMANCE:

Dampers are designed to operate in a clean, dry environment.
Maximum System Pressure: 2" w.g. (500 Pa).
Maximum Face Velocity: 2000 fpm (10 m/s).

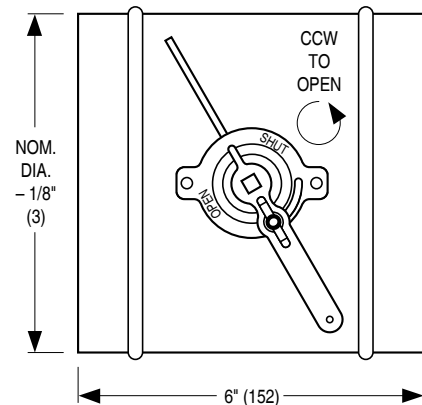
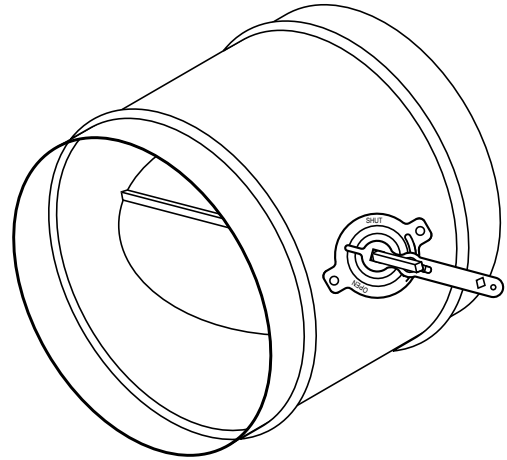

SCHEDULE TYPE:				
PROJECT:				
Dimensions are in inches (mm)				
ENGINEER:	DATE	B SERIES	SUPERSEDES	DRAWING NO.
CONTRACTOR:	4 - 17 - 24	610R	New	610R-3