

Actuator Weather Shield & Installation Instructions- Model WS2

Design Features – Dowco’s Actuator Weather Shield provides moderate protection against weather conditions for actuators mounted outdoors. It is not designed as a watertight enclosure, but prevents extreme exposure to harsh elements that may cause damage to the actuator. Two knockout holes along the base allow for easy conduit connection to the housing.

STANDARD CONSTRUCTION

WEATHER SHIELD:

.040" thk. aluminum, alloy 3003-H14- Standard
18 gauge galvanized steel

FINISH:

If applied to louver, upon request weather shield can match louver finish.

GASKET:

1/2" x 1/8" Neoprene Gasket

COMPATIBILITY:

Honeywell Motors
Siemens Motors
Belimo Motors

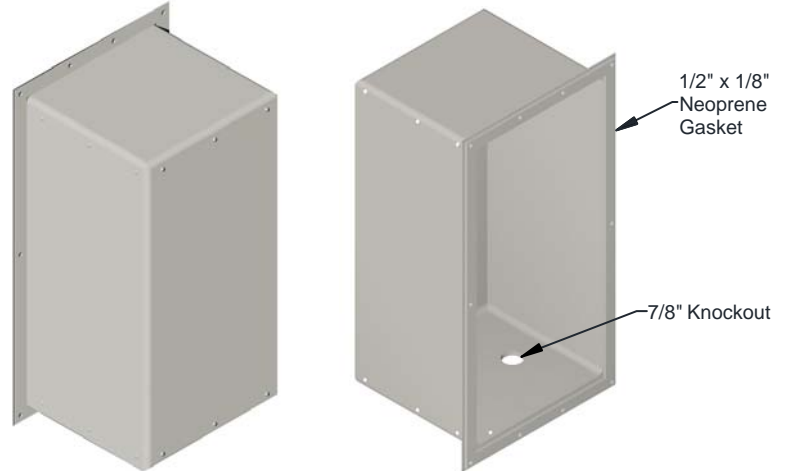

OPTIONAL CONSTRUCTION

MATERIAL- Available in a heavier gauge.

FINISH – Available in Galvanized, Stainless Steel or as requested.

INSTALLATION:

1. Installer must be a trained technician and read instructions thoroughly before beginning installation.
2. Check for damages that may have occurred during shipment. Weather shield shall be shipped as a single piece with pre-attached neoprene gasket.
3. Check to make sure actuator is appropriate and capable of fitting within weather shield dimensions.
4. Install the actuator as required by actuator instructions.
5. Adjust actuator anti-rotation strap to fit inside the weather shield, if necessary.
6. Locate actuator wires and thread through pre-drilled knockouts located at the base of the weather shield.
7. Center the weather shield around the actuator and onto the louver/damper.
8. Using self-tapping screws, drill weather shield into place. Use plastic plugs to cover any unused holes.
9. After securing weather shield onto louver/damper, run a test to check that screws do not interfere with blade movement.

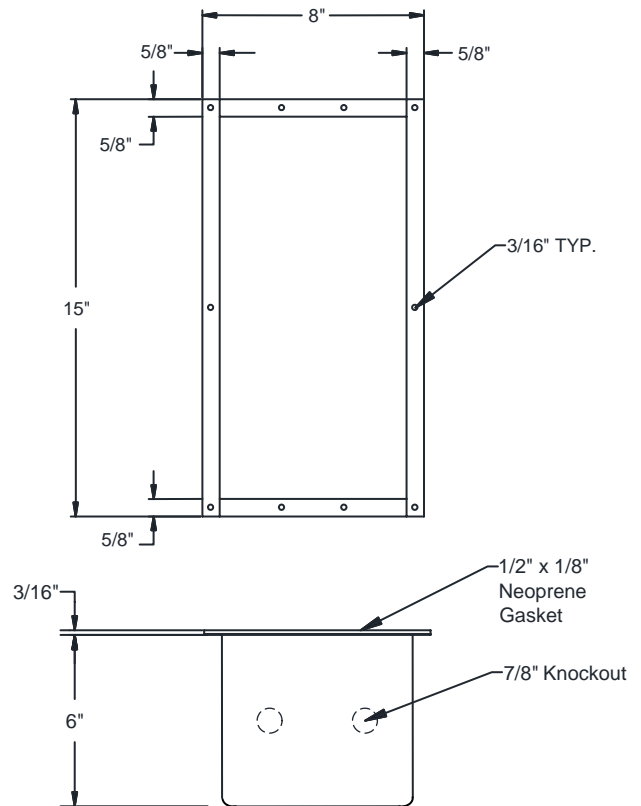

| | | | | |
|---------|--------------------|---|---|-------------|
| DATE | ARCHITECT/ENGINEER | | | CUSTOMER |
| PROJECT | | | | |
| ITEM | QTY | W | H | DESCRIPTION |
| | | | | |
| | | | | |
| | | | | |
| | | | | |
| | | | | |



DEPENDABLE PRODUCTS SINCE 1955

SAFE-AIR OF ILLINOIS INC.

Engineering and General Offices

1855 South 54th Avenue, Cicero, Illinois 60804

Phone 708-652-9100 FAX 708-652-9158